

Operating instructions

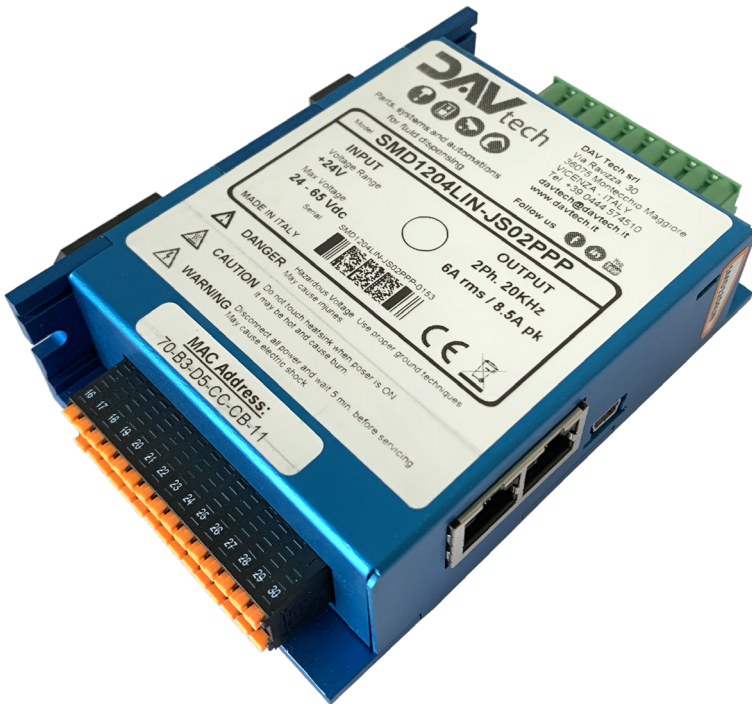

GEAR VOLUMETRIC PUMP DRIVE



DAV TECH SRL

Via Ravizza, 30 - 36075 Montecchio Maggiore (VI) - ITALIA

Tel. 0039 0444 574510 - Fax 0039 0444 574324

davtech@davtech.it - www.davtech.it

Index

1 INTRODUCTION	pag. 3
1.1 The manual	
1.2 Warranty	
1.3 Goods receipt	
2 TECHNICAL DESCRIPTION	pag. 3
2.1 Operation	
2.1 Technical specifications	
3 SAFETY STANDARDS	pag. 4
3.1 Safety notes	
4 INSTALLATION	pag. 10
4.1 Panel installation	
4.2 Thermal dissipation	
4.3 Electrical connections	
4.4 Power supply	
4.5 Ground connections	
4.6 Power connector	
4.7 Control connector	
5 CONNECTION DIAGRAM	pag. 16
5.1 Power disconnect-switch	
5.2 Encoder signals	
5.3 Drive logic	
5.4 Interfacing via Profinet	
5.5 Interfacing via Modbus Tcp/Ip	
7 WIRING DIAGRAM	pag. 24

1 INTRODUCTION

1.1 The manual

The user manual is the document that accompanies the pump from the moment of its construction and for the entire period of use, it is therefore an integral part of the pump. The manual must be read before undertaking any operation involving the pump. The manual must be readily available to personnel assigned to use and maintenance of the pump. The user and the person responsible for use are required to know the contents of this manual. Reproduction of any part of this manual, in any form, without the express written permission of DAV Tech is prohibited. The texts and illustrations contained in the manual are not intended to be binding, DAV tech reserves the right, at any time and without notice, to make any changes to improve the product or for constructive or commercial needs.

1.2 Warranty

The warranty is valid for a period of 12 months starting from the commissioning date and in any case not later than 15 months from the delivery date. Interventions carried out during the warranty period do not in any way extend the warranty period. The seller is not liable for defects due to the normal wear of parts which, by their nature, are subject to wear.

1.3 Goods receipt

Upon receipt of the goods, check that:

- The packaging is intact.
- The exact correspondence of the ordered material.

The original drive configuration must definitely not be changed.

2 TECHNICAL DESCRIPTION

2.1 Operation

The controller was created to manage the movement of a GP pump with DC motor with feedback from an encoder.

The SMD1204PN controller has Profinet IO and Modbus TCP / IP connectivity via ethernet, this allows the drive to be controlled by most PLCs.

The device internally manages a " Modbus Server" in addition to the IO Device, it must therefore be interrogated by another Client device to read and write data.

The configuration of the Profinet interface can be managed directly from the development PLC tool used, as the functions for assigning the device name and ip address are standard and are already managed directly by the drive.

The parameterization and the programming of the drive is simple and fast thanks to Step Control, the Tool supplied with an advanced graphic interface for Windows able to communicate with the drive both with USB and with Ethernet.

The drive already contains a software that manages the GP pump in all its aspects, enabling, dispensing, suck-back function, possible outlet valve etc., this program can be parameterized with the variables exchanged with the PLC via Profinet or Modbus TCP / IP.

2.1 Technical specifications

Output current	Rated current	A_{RMS}	4
	Peak current	A_{RMS}	8
Supply	Voltage range	V_{DC}	+24 .. 85
	Rated voltage	V_{DC}	+65
Current control	Type		Dual MOSFET H-bridges
	Frequency	KHZ	20 (50 μ s)
	PWM outputs		20 KHz center-weighted PWM
Protections			Short circuit, overvoltage, undervoltage, T, pursuit, position
Feedback			Incremental line driver or push pull encoder (PNP o NPN)
Input digital general purpose	Number		9 + 3 (superimposed on the service inputs)
	Type		PNP TTL compatible up to +30 VDC
	Function		configurable via software
Output digital general purpose	Number		4
	Type		PNP +24 VDC
	Current	mA	100 per channel
	Protection		Temperature, short circuit
	Function		Configurable via software
Service Digital Input	Number		6 (superimposed on general purpose inputs)
	Type		PNP o NPN da 5 a 30 VDC
	Current consumption	mA	8
	"High" / "Low" level threshold	V_{DC}	> + 2,2/ < + 0,8
	Features		High-speed inputs
Analog input	Number		3 (optional)
	Resolution	bit	12
	Range	V_{DC}	0 ... +10 (+/- 10V optional on Ana.inp. and Ana.inp.1)

Operating instructions

3 SAFETY STANDARDS

It is recommended to follow the instructions below in order to avoid damage to the system, the device, or injury to the technician, or to other people during operation.

Throughout this manual, the following symbols are used to indicate the possible danger levels if the installation instructions are not followed.



DANGER

Indicates conditions that could result in death or serious injury if the given precautions are not observed.



ATTENTION

Indicates conditions that could result in death or serious injury if the given precautions are not observed.

The following symbols indicate the operations that must be done and the prohibited operations.



NOT ALLOWED

Indicates prohibited actions that must NEVER be performed.



OBLIGATORY

Indicates actions that MUST be performed.

The following symbols are used to indicate information useful for a correct installation. (Assistance)



IMPORTANT

Indicates important information to be memorized including precautions such as displaying alarms to avoid damaging devices.



INFORMATION

Indicates additional information.

**DANGER**

Read the following instructions in their entirety before checking the products at the time of delivery, before transport and storage, installation, wiring, operation, inspection, and disposal.



Make sure you have correctly connected the connectors and fixed the cables.

Incorrect wiring can cause electric shock, fire, equipment damage or injury.



Do not expose cables to sharp objects or edges, excessive pressures or traction, or to objects that could cause them to be crushed.

Breakage or misplacement of a cable can cause electric shock, fire, equipment damage or injury.



Do not touch any rotating part of the motor when the drive and the motor itself are operational.

Not observing this rule can cause injury.

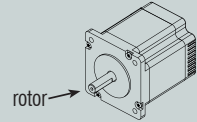

Wait at least 5 minutes after switching off before removing, modifying wiring, or inspecting the device. Only specialized personnel can perform these operations.

Not observing this rule can cause electrical shocks.



Never touch the inner parts of the drive.

Failure to observe this warning can result in injury.



Do not remove cables, connectors, protective or optional elements while the power supply is on, or in the absence of the appropriate safety systems.

Failure to observe this warning can cause electric shock or equipment damage.



Do not approach the machine immediately after resetting a momentary power failure, to avoid unexpected restarts.

Failure to observe this warning can result in injury.



Do not touch the motor or the drive during operation. The surface may reach high temperatures.

Not observing this warning can cause burns.



Do not subject the product to water, corrosive liquids, flammable gases or combustible gases.

Not observing this rule can cause fires.



REQUIRED



During installation, protections must be provided for over-currents, for electricity leakage, for over-temperatures, as well as emergency stop devices.

Failure, in the absence of protection, can cause electrical shock, injury or fire.



Strictly follow the instructions and procedures contained in this manual to verify the correct installation.

Malfunions that occur, due to incorrect installation, damage the equipment and can cause accidents or serious injuries.



Installation, wiring, and consultancy relating to inspections and malfunctions must only be carried out by authorized personnel.

Failure to observe this warning can cause electrical shock, injuries, fires, damage, or malfunctions.



Install an emergency stop device on the machine to ensure its safety.

Failure to observe this warning can cause electric shock, injury, fire.



Applications and installations must meet all applicable safety requirements.

Failure to observe this warning can result in injury.



Make sure that the devices have been properly grounded. Connect the grounding terminal, in compliance with the regulations for electrical installations. (Ground resistance $<100\Omega$)

Not observing this rule can cause electrical discharges.



Use properly sized equipment for the type of load to be handled.

Failure to observe this warning can result in equipment damage or injury.



ATTENTION



Do not carry the drive or motor holding it by the cables or the motor shaft.

Failure to observe this warning can result in malfunctions or injuries.

**Do not apply loads higher than those indicated in the technical documentation.**

Failure to observe this warning can result in malfunctions or injuries.

**Do not cover the drive inputs, outputs and ventilation slots and prevent foreign bodies, such as metal or liquid fragments, from entering the product.**

Failure to observe this warning can cause deterioration of the internal components with consequent fires or malfunctions.

**DAV Tech products are precision equipment. Avoid violent shocks during transportation, installation, and operation.**

Failure to observe this warning can cause malfunctions.

**Do not store or install the product in the following places:**

- Places with temperature outside the allowed ranges.
- Places with humidity levels outside the allowed ranges.
- Places subject to condensation formation due to thermal excursions.
- Places exposed to corrosive, explosive or flammable gases.
- Places exposed to dust, saline agents, or metal powders.
- Places exposed to water, oils or chemical agents.
- Places subject to shock or vibration.

Failure to observe this warning can result in malfunctions or damage to the product.

**Do not step or place heavy objects on the product.**

Failure to observe this warning can result in malfunction or injury.

**Be sure to comply with all the installation conditions.**

Failure to observe this warning can malfunction, fire or electric shock.

**Power the drive only with voltages isolated from the mains voltage and included within the admissible limits.**

Failure to observe this warning can cause malfunctions, fires or electric shocks.

**Make sure you have connected the product correctly.**

Failure to observe this warning can cause malfunctions.

**Keep the specified distances between the drive and other devices.**

Failure to observe this warning can cause malfunctions or fires.

Operating instructions



Securely connect the power terminals. Use cables with a section suitable for their use.

Failure to observe this warning can cause a fire.



Keep the power and signal lines at a distance of at least 300mm. Use twisted pairs or shielded cables.

Failure to observe this warning can cause malfunctions.



Perform the motor operating tests only with the drive shaft disconnected from the machine.

Failure to observe this warning can cause serious injuries.



When disposing of the products, consider them as general industrial waste.

3.1 Safety notes

DAV Tech automation products must be handled, installed, and maintained only by competent personnel trained in the installation of automation components, and only for the purposes described in the user manual. The technician must pay particular attention to potential risks caused by mechanical and electrical hazards.

It is very important that applications and installations meet all applicable safety requirements.

Each technician is obliged to take responsibility for verifying his / her knowledge and understanding of all applicable safety standards.

Any use that does not comply with the safety requirements can damage the equipment and injure the user.

DAV Tech Srl will not be held responsible and will not assume any responsibility for damages caused by products handled and / or installed improperly, or in cases where the customer has allowed, or performed, modifications and / or repairs not authorized by DAV Tech Srl.

General precautions

- The illustrations in this manual are typical examples and may differ from the product received.
- This manual is subject to change due to product improvements, specification changes or improvements to the manual.
- DAV Tech srl is not responsible for damage to things and / or people caused by incorrect installations and / or unauthorized modifications of the product.

European directives



NORMATIVA	DESCRIZIONE	DATA
89/336/EEC	EMC Directive	3-may1989
EN 55011	Limits and methods of measurement of radio disturbance characteristics of industrial, scientific and medical (ISM) radio-frequency equipment	15-Sep-1998
93/68/EC	CE Marketing - Low voltage	22-Jul-1993
98/37/EC	Machinery	22-Jun-1998
EN 60204-1	Safety of machinery - Electrical equipment of machines	30-Jun-2006
2002/95/CE	RoHs Directive	27-Jan-2003

NOTE. Since the drives are of an integrated type, they need a new confirmation after installation in the final product.

Operating instructions

4 INSTALLATION

FEATURE	SPECIFIC	
Operating temperature	0°C ... +50°C	
Cooling	Ventilate the drive in case of continuous operation	
Operating humidity	95% relative or lower humidity (without condensation)	
Storage temperature	-20°C ... +70°C	
Storage humidity	95% relative or lower humidity (without condensation)	
Place of installation	Free of corrosive gases Free of dust and iron powder Not subject to moisture or lubricating oil such as cutting oil	
Altitude	1,000 m or less	
Vibration resistance	4,9 m/s ²	
Shock resistance	19,6 m/s ²	
Operating conditions	Installation category (overvoltage category): III Pollution degree: 2 or better Protection class: IP3X (EN50178)	
Place of installation	Installing in a control panel	Design the control panel size, module layout and cooling method so that the temperature around the drive does not exceed 50 ° C. Note: To increase product life and maintain reliability, keep the temperature inside the control panel below 40 ° C.
	Installation near a heating module	Minimize thermal radiation from the heating module and any temperature rises caused by natural convection, so that the temperature around the drive does not exceed 55 ° C.
	Installation near a vibration source	Install a vibration damper below the drive to avoid subjecting it to excessive vibration.
	Installation in a place exposed to corrosive gases	Corrosive gases do not have an immediate effect on the device but, in the long term, cause malfunctions of the electronic components. Take appropriate measures to avoid the presence of corrosive gases.

Operating instructions

4.1 Panel installation

If installed inside an electrical panel, leave a free space of at least 50 mm around the module in case of the installation of a single drive. If more drives are installed, respect the minimum space, as shown in the following figure, between two contiguous drives, in order to guarantee air flow and cooling of the modules.

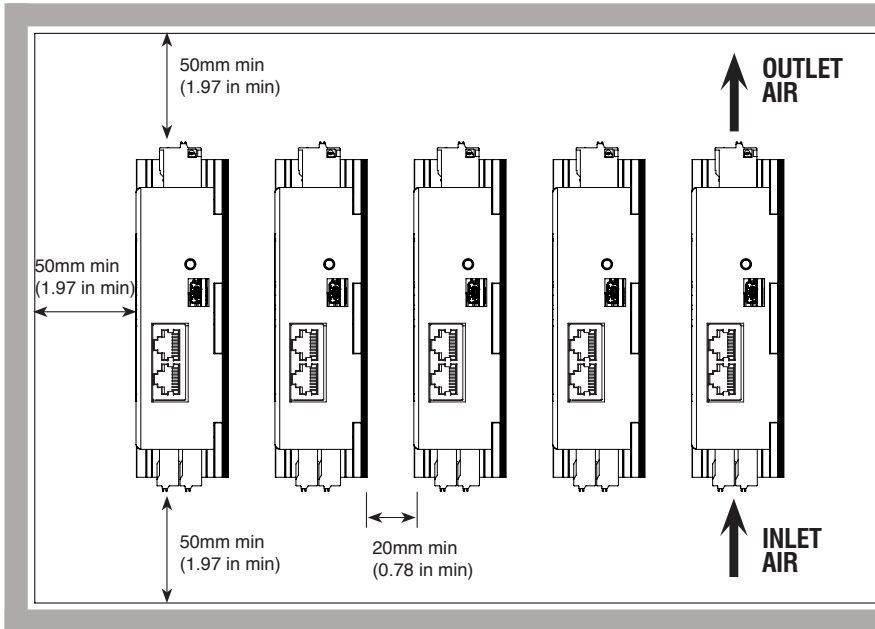

ATTENTION



**Do not cover the ventilation slots and prevent foreign bodies, such as metal fragments, liquids or combustibles, from entering the product.
It is expressly forbidden to undertake actions aimed at modifying any mechanical part of the drive.**

Failure to observe this warning can cause internal components to deteriorate, resulting in fires or malfunctions.

4.2 Thermal dissipation

The trend of the thermal dissipation in relation to the supplied current is shown below.

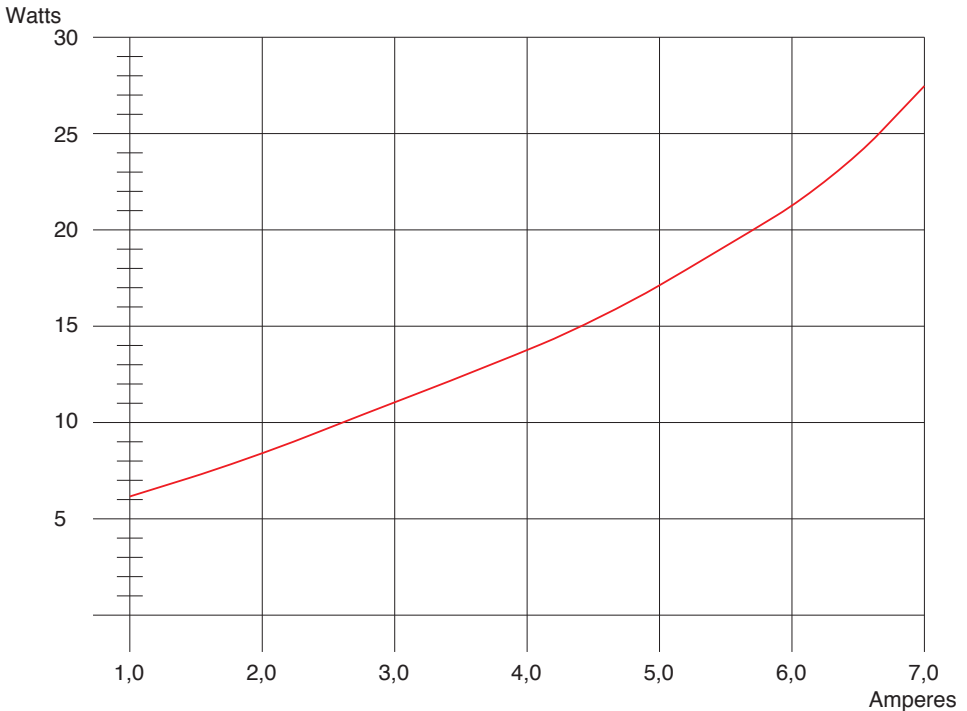

The electric current required to control the gear volumetric pumps is 6.6 A.

4.3 Electrical connections

Below is the trend of the thermal dissipation in relation to the supplied current.



ATTENTION

- Avoid short-circuits, incorrect mass conductor connection, and polarity inversions.
- Check the voltage levels before plugging in the power connector.
- Always connect the ground terminal.

Operating instructions

4.4 Power supply

The drive power supply will be 24VDC as it is also the rated voltage of the motor.

The drive has 2 separate power supplies, one for the logic and one for the power, this is to make it possible to cut the power of the pump from a safety circuit, even if the pump is not considered dangerous as it has no moving part on the outside. The maximum absorption for a gear volumetric pump is about 6.5A while the drive logic is about 200-300mA.

It is advisable to use cables with a minimum section of 1 mm² for connections with a length of less than 20 m and at least 2.5 mm² in the case of connections with a longer length (maximum length allowed = 20 m).

Use 4- core twisted pair and shielded cables.

4.5 Ground connections

It is preferable to use a ground bar that acts as a collector especially if there are several drives connected.

It is important to connect to ground:

- the gnd of the power supply
- the drive housing
- the expected connection provided on the power terminal board
- the power cable screen (connected via the terminal of the power terminal board)
- the encoder cable screen.

4.6 Power connector

The power connector is used to:

- bring power to the drive
- connection of the motor power supply

The connector carries the following wire diameters and tips

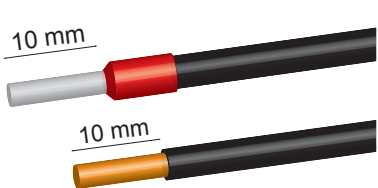

CONDUCTOR CHARACTERISTICS	mm ²
Rigid conductor section	0,2 - 2,5
Flexible conductor section	0,2 - 2,5
Flexible conductor cross section with cable lug without collar	0,2 - 2,5
Flexible conductor section with ferrule with collar	0,2 - 2,5
Stripping length or cable lug length	10

To reduce EMI disturbances, it is required to install a ferrite filter at a maximum distance of 150 mm from the drive on the motor cable.

The filter is composed of low-grade ferrite which has high radio frequency losses; in this way the filter works as a high impedance at those frequencies.

Recommended ferrites:

MANUFACTURER	FAIR-RITE	WÜRTH ELEKTRONIK
Code	1463444	74271132
Outer diameter	23,7 mm	24,5 mm
Inner diameter	10,15 mm	8,5 mm
Length	39,4 mm	40,5 mm
25 MHz impedance	144 Ω	141 Ω
100 MHz impedance	240 Ω	241 Ω

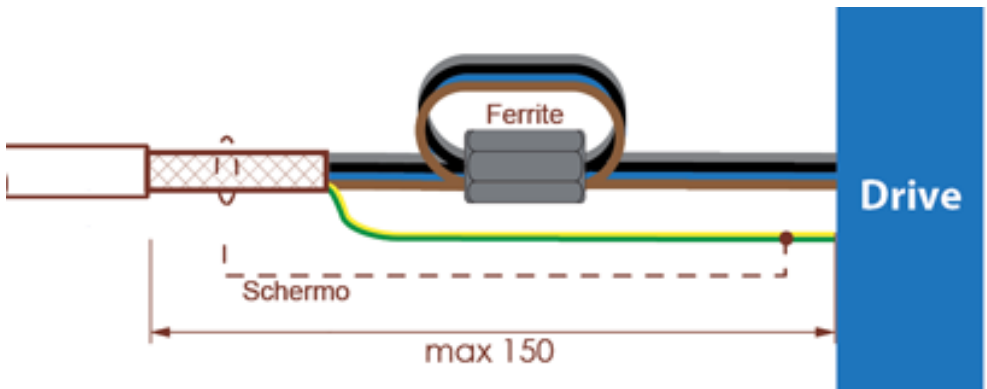

4.7 Control connector

Instead, the control connector provides:

- to supply power to the IO side of the drive
- connection of the encoder signals
- connection of the digital inputs and outputs
- connection of the analog input



ATTENTION! The digital outputs are protected against overloads (Max 500mA) and short-circuits; in case of overload the output will switch off until the anomaly is removed. If inductive loads, such as relays, solenoid valves, etc. have to be driven, connect a flyback diode in parallel to the load.

5 CONNECTION DIAGRAM

Typical connection

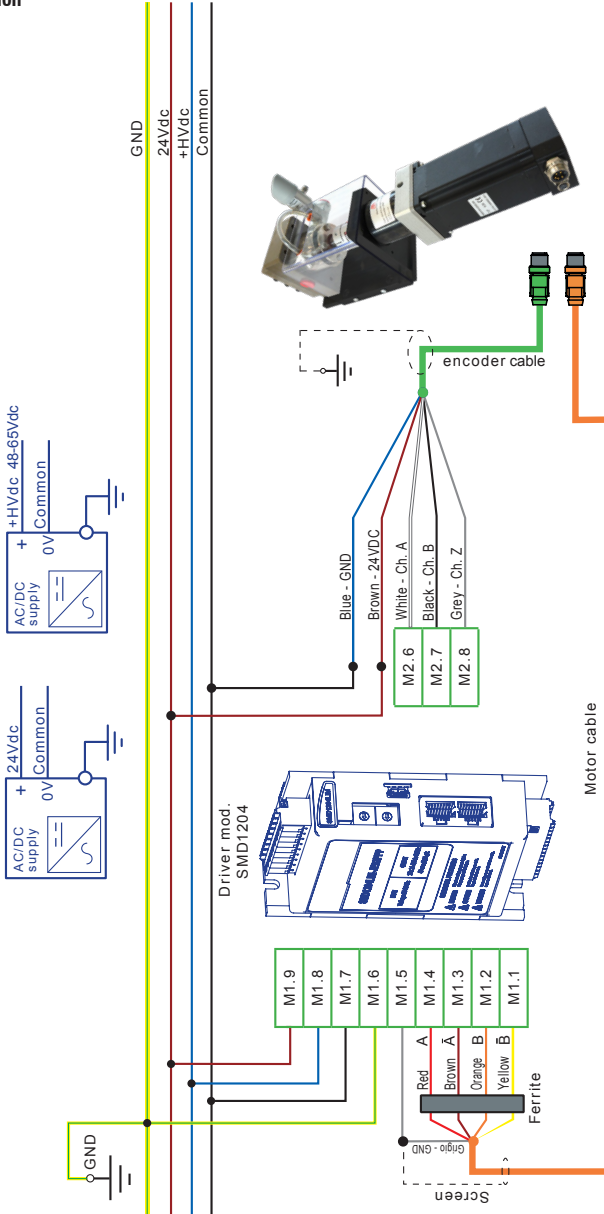

Connect together all the commons of the power supplies and signals present in the terminal blocks.

Components identification

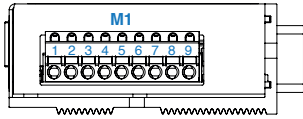

Power supply and motor connector (M1)

PIN	Signal name	Description
1	Phase B-	Output Phase B-
2	Phase B	Output Phase B
3	Phase A-	Output Phase A-
4	Phase A	Output Phase A
5	Ground	Ground
6	Ground	Ground
7	Common	Negative supply voltage DC
8	Power supply	Positive power supply voltage DC (48-65 Vdc)
9	Logic supply	Voltage backup +24Vdc

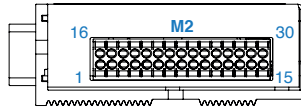

Service input connector (M2)

PIN	Signal name	Description
1	+5 Vdc out (max 100mA)	Uscita +5 Vdc (max 100 mA)
2	Common encoder	Common encoder inputs
3	Motor encoder A-	Channel A- motor encoder
4	Motor encoder B-	Channel B- motor encoder
5	Motor encoder Z-	Channel Z- motor encoder
6	Motor encoder A+ / Inp. 5	Channel A+ enc. motor / Input dig. 5
7	Motor encoder B+ / Inp. 6	Channel B+ enc. motor / Input dig. 6
8	Motor encoder Z+ / TOP / Inp. 7	Channel Z+ enc. motor / TOP input / Digital Input 7
9	External encoder A+ / FLS / Input 8	Channel A+ external encoder / Forward limit switch / Digital Input 8
10	External encoder B+ / BLS / Input 9	Channel B+ external encoder / Reverse limit switch / Digital input 9
11	External encoder Z+ / Inp. 0	Z+ Channel External Encoder / Digital Input 0
12	Digital input 1	Digital Input 1
13	Digital Output 0	Digital Output 0
14	+5 Vdc out (max 100mA)	Output +5 Vdc (max 100 mA)
15	SSP_OK_IN	Ticket SSP OK
16	+5 Vdc out (max 100mA)	Output +5 Vdc (max 100 mA)
17	Common encoder	Common encoder inputs
18	SSP_OK_OUT	Output SSP OK
19	Analog output	Analog output
20	Analog common	Common analog in/out
21	Analog input	Analog input
22	Ana. Inp.1 / Output 2	Analog input 1 / Output 2
23	Ana. Inp.2 / Output 3	Analog input 2 / Output 3
24	External encoder A-	Channel A- external encoder
25	External encoder B-	Channel B- external encoder
26	External encoder Z-	External Z- encoder Channel
27	Digital input 2 / Output 6	Digital Input 2 / Digital Output 6
28	SSP IN 1	Input SSP 1
29	SSP IN 2	Input SSP 2
30	Digital output 1	Digital Output 1

Operating instructions

The program inside the drive already provides the following connections on the M2 connector:

PIN	CONNECTION NAME	PROGRAMME FUNCTION
1	5 VDC encoder	Not used
2	GND encoder	Not used
3	Channel A - encoder	Not used
4	Channel B - encoder	Not used
5	Channel Z - encoder (Top)	Not used
6	Channel A+ encoder	Channel A encoder
7	Channel B + encoder	Channel B encoder
8	Channel Z + encoder	Channel Z encoder
9	Channel A + encoder external / input 8	Predetermined dispensing
10	Channel B + encoder external / input 9	Alarm reset
11	Channel Z + encoder external / input 0	Not used
12	Input 1	Enable
13	Output 0	Alarm
14	5 VDC	Not used
15	Reserved	Reserved
16	5 VDC external encoder	Not used
17	GND (internal connected pin 20)	GND
18	Reserved	Reserved
19	Analog output	Not used
20	Analog GND	Analog GND
21	Analog Input 0 (0-10V)	Pressure sensor
22	Output 2	End dispensing
23	Output 3	Dispensing in progress
24	Channel A - encoder external	Not used
25	Channel B - encoder external	Not used
26	Channel Z - encoder external	Not used
27	Input 2	JOG Dispensing
28	Input SSP1	Input 1 electronic power disconnecter
29	Input SSP2	Input 2 electronic power disconnecter
30	Output 1	Ready drive

All signals are PNP.

5.1 Electronic power disconnecter

Using SSP 1 and SSP 2 input, it is possible to control the electronic disconnecter integrated into the drive with both 24 V signals and to supply the power stage of the drive.

5.2 Encoder signals

The drive prepares a connection for the differential and push-pull type encoder signals, therefore connect the encoder directly to the drive.

5.3 Drive logic

The drive has been designed to perform all the dispensing functions necessary for a gear volumetric pump, these functions can all be parameterized via Modbus TCP/IP, without this communication it will be possible to use the drive with only one static data set.

By using the inputs or variables via Modbus it is possible to activate the following functions in the drive:

Enable (Power Enable)

With input 1 it is possible to couple the pump motor, if the power supply is missing or the pump is physically disconnected, the drive will give the power timeout alarm.

Jog Dispensing

With input 2 it is possible to activate the pump to dose at constant speed, by turning off the command the pump will stop immediately.

Predetermined dispensing

With input 8 it is possible to activate the dispensing of a set quantity, the input must be kept active until the end of dispensing, the "End of dispensing" signal will then be activated when the command is switched off.

Alarms reset

The designated input is input 9.

Suck back

The drive automatically performs the suck back (inversion of the rotation); whenever the controlled pump stops, the direction of rotation is reversed with programmable speed and quantity.

INPUT	PIN	Description
IN 1	12	Enable
IN 2	27	Jog dispensing
IN 8	9	Predetermined dispensing
IN 9	10	Reset

Operating instructions

There are also 4 outputs that define the drive's status:

Alarm

When 1 or more hardware alarms are active in the drive

Ready

When there are no alarms and the motor is in torque (enable active)

End of dispensing

Signal that activates at the end of a predetermined dispensing

Dispensing in progress

Signal that allows you to connect for example a solenoid at the output of the pump (with a programmable delay)

INPUT	PIN	DESCRIPTION
OUT 0	13	Alarm
OUT 1	30	Ready
OUT 2	22	End of dispensing
OUT 3	23	Dispensing in progress

Pressure sensor

It is possible to connect a pressure sensor on the pump delivery with full scale of 200 bar, with 0-10V output (see wiring diagram).

5.4 Interfacing via Profinet

The drive in the upper part has 2 ethernet ports which are related to a single network interface. It is possible to insert one or more drives into the PLC network configuration using the supplied GSDML file. The real time data exchange must be configured in the Drive using the "PROFIdrive AEC Telegram 500" (programmable delay).

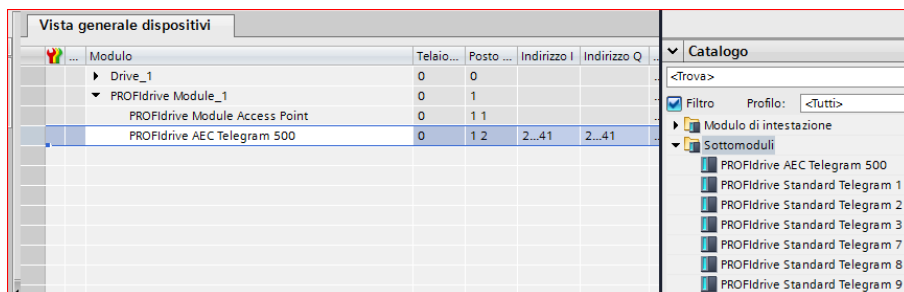

This telegram sets up the exchange of 10 INT32 variables for the inputs and 10 INT32 variables for the outputs (40 + 40 Byte).

PLC input	Drive variables	Modbus holding register	Description
Var_1	V111	4-1222	Status Bit 0 alarm Bit 1 Ready Bit 2 End of dispensing Bit 3 Dispensing Bit 4 Power Enablement Alarm Bit 5 Standby Bit 6 Pressure alarm
Var_2	V112	4-1224	Encoder position Relative position of the encoder, it is reset at the end of the jog dispensing and at the completion of the predetermined one. Remains with discontinued predetermined dispensing. (200 bar sensor)
Var_3	V113	4-1226	Pressure Outlet pressure in hundredths of a bar
Var_4	V114	4-1228	Analog input Value of Analog input 4095 = 10V=200bar
Var_5	V115	4-1230	Last dispensing pressure Pressure of the last dispensing in hundredths
Var_6	V116	4-1232	Rstflag Drive RSTFLG register value Bit 0: Drive enabled Bit 1: Alarm drive Bit 2: Synchronized Motor Share (Axis Reset) Bit 3: Motor running Bit 4: Motor accelerating Bit 5: Motor at constant speed Bit 6: Motor in deceleration Bit 7: Information in the Rstscllp register Bit 8: Home terminated with error Bit 9: Current Status (0=CurOff/1=CurON) Bit 10: Motor in position Bit 11: Tracking Error Bit 12: Motor moved during disable state
Var_7	V117	4-1234	Ralarm Drive RALARM register value 0 Overcurrent HW 1 Overcurrent SW 2 I2T 3 Position error 4 Tracking error 5 Overload digital output 6 Overtemperature 7 Overvoltage 8 Undervoltage 9 Encoder timing error 10 Phase A disconnected motor 11 Phase B disconnected motor 12 Positioning Timeout 13-15 Reserved
Var_8	V118	4-1236	Pid out Not used in Mode 0
Var_9	V119	4-1238	Out speed Not used in Mode 0
Var_10	V120	4-1240	Current error Not used in Mode 0

Operating instructions

PLC input	Drive variables	Modbus holding register	Description
Var_1	V101	4-1202	Commands Bit 0 Free Bit 1 Enable Bit 2 Continuous dispensing Bit 3 Predetermined dispensing Bit 4 Alarms reset Bit 5 EV Output Command
Var_2	V102	4-1204	Dispensing speed in rpm
Var_3	V103	4-1206	Dispensing quantity Dispensing steps 2048 = 1 motor complete rotation
Var_4	V104	4-1208	Suck back speed Suck back speed in rpm
Var_5	V105	4-1210	Suck back amount Suck back steps 2048 = 1 motor complete rotation
Var_6	V106	4-1212	Ramp acceleration and deceleration in Rps ² *100
Var_7	V107	4-1214	Maximum pressure Maximum permissible pressure in cents. When "0" control disabled
Var_8	V108	4-1216	Mode Must be set to 3
Var_9	V109	4-1218	Delay dispensing Delay between dispensing control and pump handling when use of valve connected to the output "Dispensing in progress"
Var_10	V110	4-1220	Suck back delay Suck back delay into ms

5.5 Interfacing via MODBUS TCP/IP

The drive in the upper part has 2 ethernet ports which are related to a single network interface, the ethernet parameters of the drive can be configured through a “Step Control” program that will be supplied with the drive. The drive is a Modbus server, to implement the communication it will be necessary to implement a Modbus Client on the PLC or on the controller to read and write the variables on the drive. The variables of the Drive program are exchanged using the 16Bit Modbus Holding registers. The program variables, being 32-bit, use 2 consecutive holding registers and it is necessary to pay attention to the endian of the controller used compared to the one configured on the drive. In the Profinet interface table it is possible to see the reference addresses of the variables in the Modbus holding register column. When implementing the Modbus Client, it must be considered that in some functions already implemented as for Siemens PLCs, the index of the Modbus register is shifted by 1 forward, for example the “Modbus Commands” register will be between register 1203 and 1204.

To give the correct commands to the pumps it is also necessary to consider the reducer present on each model:

- GP 06, 2, 4, 10

An FB block is available on request for Siemens S7 1200/1500, which completely manages the communication with the drive.

The programming of the IP ADDRESS for the only Modbus TCP / IP communication can be done through the specific software supplied Step CONTROL.

Operating instructions

6 ELECTRICAL DIAGRAM

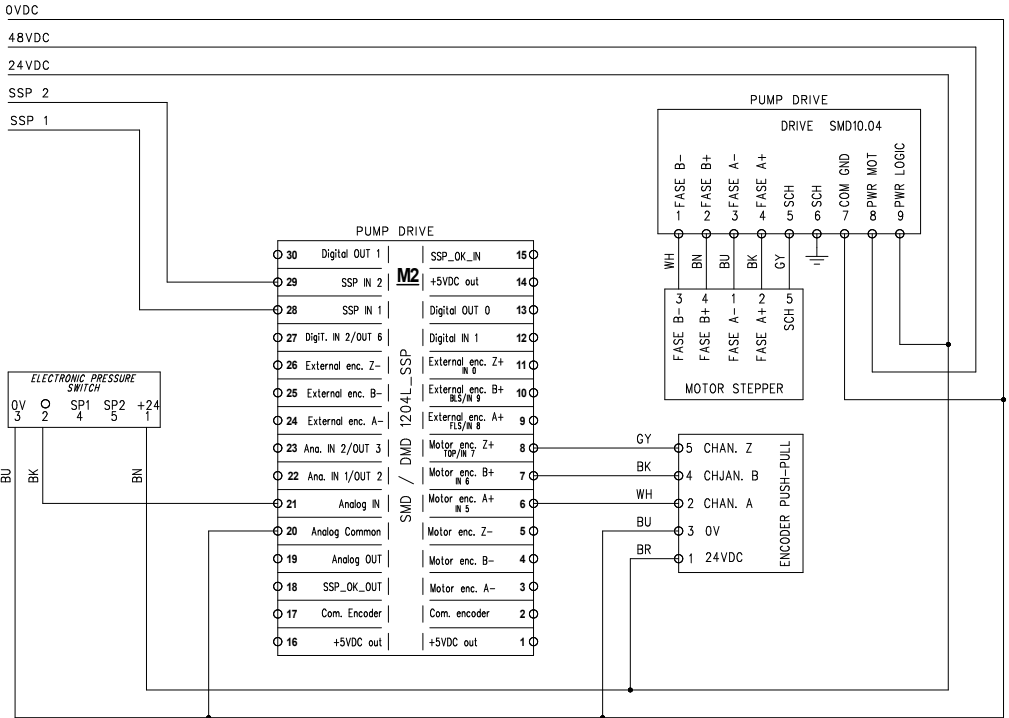

DAV TECH SRL Via Ravizza, 30 - 36075 Montecchio Maggiore (VI) - ITALY - Ph. 0039 0444 574510 - Fax 0039 0444 574324
 davtech@davtech.it - www.davtech.it

We reserve the right to modify at any time, without notice, the technical characteristics, dimensions and weights indicated in this manual. Illustrations are not challenging.