

USE AND MAINTENANCE MANUAL

MANUAL DA-400 NEEDLE DOSING VALVE



Summary

- 1 GENERAL INFORMATION..... 1**
 - 1.1 SYMBOLOGY..... 2
 - 1.2 REFERENCE STANDARDS 3
 - 1.3 DECLARATION OF INCORPORATION (ANNEX II B DIR. 2006/42/EC) 4
 - 1.4 GLOSSARY..... 5
 - 1.5 SERVICE AND MANUFACTURER CONTACT DETAILS 6
- 2 PRESENTATION AND OPERATION 7**
 - 2.1 EXPLODED..... 11
 - 2.2 TECHNICAL DATA 13
- 3 SAFETY 15**
 - 3.1 COMPONENT SAFETY DEVICES..... 16
 - 3.2 FREE USEFUL SPACES 16
 - 3.3 RISK AREAS AND RESIDUAL RISK 16
- 4 TRANSPORT AND HANDLING..... 16**
- 5 INSTALLATION 17**
 - 5.1 POSITIONING..... 17
 - 5.2 CONNECTIONS..... 17
 - 5.2.1 *Electric*..... 18
 - 5.2.2 *Pneumatic*..... 18
 - 5.3 COMMISSIONING..... 19
- 6 SOFTWARE..... 19**
- 7 PROCEDURE 20**
 - 7.1 SCREW ADJUSTMENT 20
 - 7.2 MICROMETRIC ADJUSTMENT 20
- 8 MAINTENANCE 21**
 - 8.1 DISASSEMBLY AND REASSEMBLY OF THE VALVE 23
- 9 TROUBLESHOOTING..... 26**
- 10 END OF LIFE..... 26**

1 GENERAL INFORMATION

This manual contains information regarding the installation, use, maintenance and end of life of the component and provides indications for the most suitable behavior for correct operation. This manual has been designed to be simple and as straightforward as possible, with a subdivision into chapters and sub-chapters that allows you to find any information you need quickly. In addition, the manual begins by giving a general description of the contents, then an overview of the component, to arrive at aspects of safety, transport, installation and use and finally to the end of life. If you have any doubts about the interpretation or reading of this document, please contact the manufacturer.



DAV Tech declines any responsibility relating to improper use of the component. Observe the specifications in this manual.



Read this manual before handling the component or performing any action on it.



The manual is an essential safety requirement and must accompany the component throughout its life cycle.

It is the task of the end user to optimize the functionality of the component, always considering the purpose for which it was built.



You are asked to keep this manual, together with the attached documentation, in good condition, legible and complete. In addition, it must be stored in the vicinity of the component or, in any case, in a place accessible and known to all personnel who use the component itself or who must perform maintenance or inspection interventions. If the manual deteriorates or is no longer complete, a copy must be requested from the manufacturer, indicating the code of the manual and the revision.



The manual is intended for personnel who use the component (operators), who perform maintenance on it (maintenance technicians), and for personnel who must perform checks or inspections. The manufacturer is not liable for damage to the component caused by personnel who have not followed the instructions in the manual.

If you have any doubts about the correct interpretation of the information contained in this manual, please contact the manufacturer.

GUARANTEE

During the design phase, a careful choice of materials and components to be used in the project was made and they were subjected to regular testing before delivery. All elements have been designed and manufactured with an adequate degree of safety, such as to be able to withstand stresses greater than those of normal use.

The warranty is valid for a period of 12 months from the date of commissioning and in any case no longer than 15 months from the date of delivery. Work carried out during the warranty period does not extend the warranty period in any way.

The manufacturer is not liable for defects due to normal wear and tear of parts which, by their nature, decay.

1.1 Symbology

Below are the symbols that are used to give a greater impact to the importance of the concept you want to give.



ATTENTION!

Refers to a warning that could lead to minor damage (minor injuries, damage to the component requiring maintenance work).



DANGER!

It refers to a major event that could cause major damage (death, permanent injury, irreversible breakage of the component).



NOTE. Indicate relevant information or insight.



OBLIGATION. It indicates a task that must be performed, related to both the component and the manual.



REFERENCE. Links to an external document that is important to view

In addition, the list of symbols is integrated with that of the personnel responsible for using the component and its function, together with other symbols used within the manual.



Operator

A (qualified) person capable of operating the component, adjusting, cleaning, starting or resetting the component. The operator is not authorized to perform maintenance.



Mechanical maintenance technician

Qualified technician able to carry out mechanical, adjustment, maintenance and routine repair work described in this manual. He is not authorized to carry out interventions on electrical systems in the presence of voltage.



Electrical maintenance technician

Qualified technician able to carry out electrical, adjustment, maintenance and routine repair work described in this manual. It can work in the presence of voltage on electrical cabinets and junction boxes. He is not authorized to carry out interventions on the mechanical side.



Manufacturer's technician

Qualified technician made available by the manufacturer to carry out operations of a complex nature in particular situations, or in any case as agreed with the customer.

1.2 Reference standards

The reference standards and directives of this manual are the following:

Directives

- 2006/42/EC – Machinery Directive;

1.3 Declaration of incorporation (Annex II B DIR. 2006/42/EC)

Manufacturer's name: DAV Tech Srl
Address: Via G. Ravizza, 30, .36075, Montecchio Maggiore (VI)

DECLARES THAT THE ALMOST MACHINE

Component: DA 400 Valve
Model: Pressure/time dosing valve
Year: 2024
Intended use: Dispense fluid to any viscosity

COMPLIES WITH THE INCORPORATION PROVISIONS OF DIRECTIVE 2006/42/EC

The technical documentation has been drawn up in accordance with Annex VII B, as required by the following:

- Machinery Directive 2006/42/EC of the European Parliament and Council of 17 May 2006

IT ALSO DECLARES THAT:

- Undertakings are undertaken to provide, in response to a properly substantiated request from the national authorities, relevant information on this partly completed machine;
- The technical file was prepared by Andrea Grazioli, via Ravizza, 30, Montecchio Maggiore (VI), IT.

This quasi-machine cannot be used until the machinery on which it will be used is declared compliant with regulation 2006/42/EC.

Montecchio Maggiore, 19 January 2024

The legal representative

Andrea Grazioli

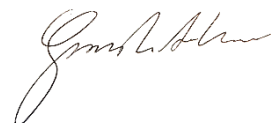

COD.: DTVI_DA400M_2404
REV.: 00
DATE: 10/07/2024

DAV TECH SRL

Any reproduction (total or partial) of this document not authorized by the manufacturer will be punished according to the law.



1.4 Glossary

The following are the most used terms within this manual with their meanings.

TERM	DEFINITION
Enable	Term that defines the act of preparing (enabling) an action. The action will be triggered as soon as the criteria are met, which consequently leads to the activation of the enabled action.
Active	The action that is performed instantaneously when the control is activated.
Human controls	This defines those commands that, used for manual operations, must be kept activated for the action to be performed. When the command is released, the action stops.
Two-hand controls	Human-controlled controls that require two manual controls to be operated simultaneously to perform an action.
P.P.E.	Personal protective equipment. They include all the items necessary to ensure the protection of personnel from possible accidental damage (safety shoes, gloves, helmet, and more).
Display	It is used to display information. It can be in any shape and size, even touch screen.
Manufacturer	Natural or legal person who designed and manufactured the component covered by this manual.
Icon	A small image that represents a command, a function or even a document or an operating program, which appears on a computer screen. When selected by the user, it initiates the function or program it symbolizes.
Joystick	Lever manipulator used in control panels.
N.A.	Not Applicable, i.e. it indicates that it is a field that does not apply to this manual and that it cannot be integrated into the component.
Operator panel	A control station where the machine control instruments are located
P.I.	Possible Implementation, i.e. it is currently absent from the component described in this manual, but it is possible to make an addition and implement it.
Screen	Interface system between man and component. Screenshots are the images displayed on the operator panel that allow the user to receive and provide information to the management software.
Push-button panel	Composition of buttons and selectors that allow you to act directly on the behavior of the component.
Keyboard	Keyboard only (stand-alone element) or in addition to a display (keys only, no selectors or other)
Touch screen	Touch screen that allows the user to interact with a graphic interface using their fingers or objects.

1.5 Service and manufacturer contact details

For any reason relating to the use, maintenance or request of spare parts, the customer must contact the manufacturer (or the service center if present) directly, specifying the identification data of the component.

The customer can make use of the technical and commercial support of local agents or importers, who are in direct contact with the company DAV Tech Srl.

Company name	DAV Tech Srl
Postal address	Via Ravizza, 30, 37065, Montecchio Maggiore (VI) – (IT)
Telephone	+39 0444 574510
Fax	+39 0444 574324
email	davtech@davtech.it
Website	www.davtech.it

2 PRESENTATION AND OPERATION

This metering valve is a pneumatically operated component designed for precision dispensing of low, medium and high viscosity fluids. Its idle state is normally closed, i.e. without pneumatic power the valve does not dispense fluid, since there is a safety spring inside the component. When the operator presses the button on the handle, the PLC sends an exchange signal to the solenoid valve which brings the power supply of at least 5 bar from its lower inlet, so the valve begins to release the fluid and, therefore, to dose. This action can be modulated both by adjusting the fluidic pressure at the inlet but also by adjusting the opening of the needle, present on its upper part. In other words, the function of this component is:

DISPENSE FLUID TO ANY VISCOSITY

Intended use is the use described in the chapter below, while improper use is considered any other use that is not described in this manual, with products of different material and format from those for which it was built.

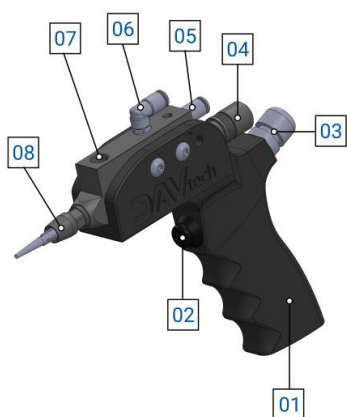

No.	DESCRIPTION
01	Grip
02	Dosing start button
03	Dosing control output
04	Micrometric adjustment
05	Air inlet closing
06	Dosing air inlet
07	Fluidic inlet
08	Fluid outlet nozzle

Figure 01 – Detail DA 400 Manual

Before using a certain type of fluid, it is necessary to check that:

- The viscosity of the fluid is compatible with the characteristics of the valve;
- The characteristics of the fluid meet the desired requirements;
- The technical data sheet of the fluid provided by the manufacturer contains all the information regarding the product such as viscosity, applications, drying times and storage;
- The fluid storage time has not been exceeded;
- The fluid packages are tightly sealed.

If it is necessary to use several fluids with the same valve, it must be cleaned thoroughly to prevent residues from the previous processing from affecting the processing to be performed.

OPERATION

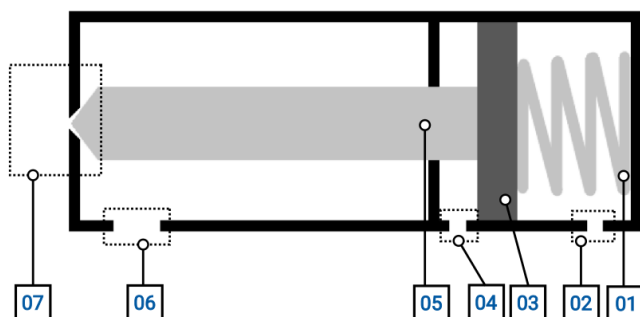

No.	DESCRIPTION
01	Spring
02	Air inlet closing
03	Piston
04	Air inlet opening
05	Pin
06	Fluid inlet
07	Nozzle engagement / fluid outlet

Figure 02 – DA 400 internal section

It can be used in two working modes:

- As a single-acting valve, with spring closure;
- Like a double-acting valve, with opening and closing by air.

Depending on the function you want to use, you must connect one of the following solenoid valves:

- To a 3/2 solenoid valve for single effect. In this case, the fluid pressure must not exceed 25 bar;
- To a 5/2 solenoid valve for double acting. In this case, the fluid pressure can be higher than 25 bar.

Figure 02 shows the most complete case. For minimum working pressures, please refer to [Chapter 2.2](#).

The valve cannot operate autonomously. To ensure that it dispenses product, it must be connected to a power source, which can be a tank, a pump or other, depending on the system and the customer's needs.

ATTENTION!



It is recommended that the valve be connected to the sources indicated in this manual in [chapter 2.2](#). Connecting it to other sources or products with features not listed in this manual may break the valve.

The valve is also equipped with a flow regulator, which is used to determine how much product to dose. In practice, the adjustment of the pin determines, together with the pressure of the material and the opening time, the quantity of product dispensed. To use the knob, you can turn clockwise to decrease the stroke of the needle and, therefore, the amount of fluid dispensed (until it is completely closed); Turning in the other direction increases the amount of fluid delivered.

Below we want to explain the operation by section of the DA 400 valve. Note that blue indicates the fluid inlet/outlet, yellow the air, when present.

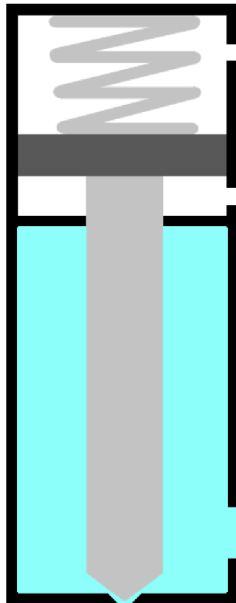

Figure 03 – Single effect resting phase

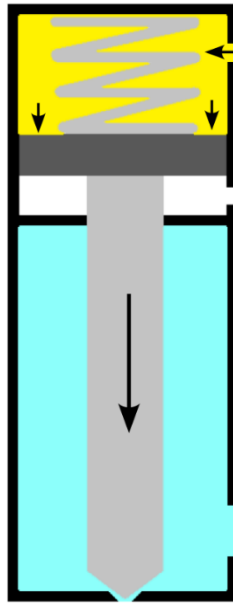

Figure 04 – Double effect resting phase

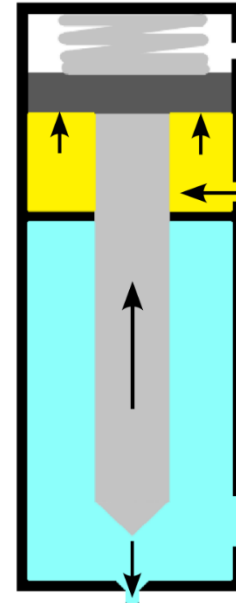

Figure 05 – Dosing phase

The valve can operate in two modes, i.e., single and double-acting.

In the case of a simple effect, what keeps the valve closed is the spring, so the fluidic pressure must be below the pressure generated by the spring to keep the valve closed (Figure 03). The fluid is located at the fluidic inlet, the inlet of which is blocked by the pin, held in place by the spring. When the button on the handle is pressed, the PLC sends a signal to the solenoid valve to change state, to let the air enter from the dosing inlet, raising the piston and, consequently, also the needle and letting the fluid pass to the nozzle (Figure 05).

In the case of double acting, the working mode is like that of single acting, except that, in addition to the spring to keep the valve closed, there is a pneumatic pressure from the closing inlet of the valve (Figure 04). This is used if you must work with fluidic pressures higher than that exerted by the spring.

So, in general, the toggle sequence is as follows:

- The fluid is under pressure in the fluidic inlet; in the case of a single effect, with only the spring pushing to close the fluid outlet (Figure 03), in the case of a double effect, with also the pneumatic pressure (Figure 04);
- Press the button on the handle and the PLC controls the solenoid valve (3/2 in the case of a single act, 5/2 in the case of a double acting) to carry out the dosing;
- In the case of double effect, the solenoid valve changes the inlet, emptying the closing inlet and opening the opening one; while, in the case of a single effect, by opening only the appropriate pneumatic inlet;
- The needle lifts, allowing the fluid to exit (Figure 05);
- When the PLC commands the dosage, the starting condition is returned, with the needle closing the fluid inlet inside the valve chamber.

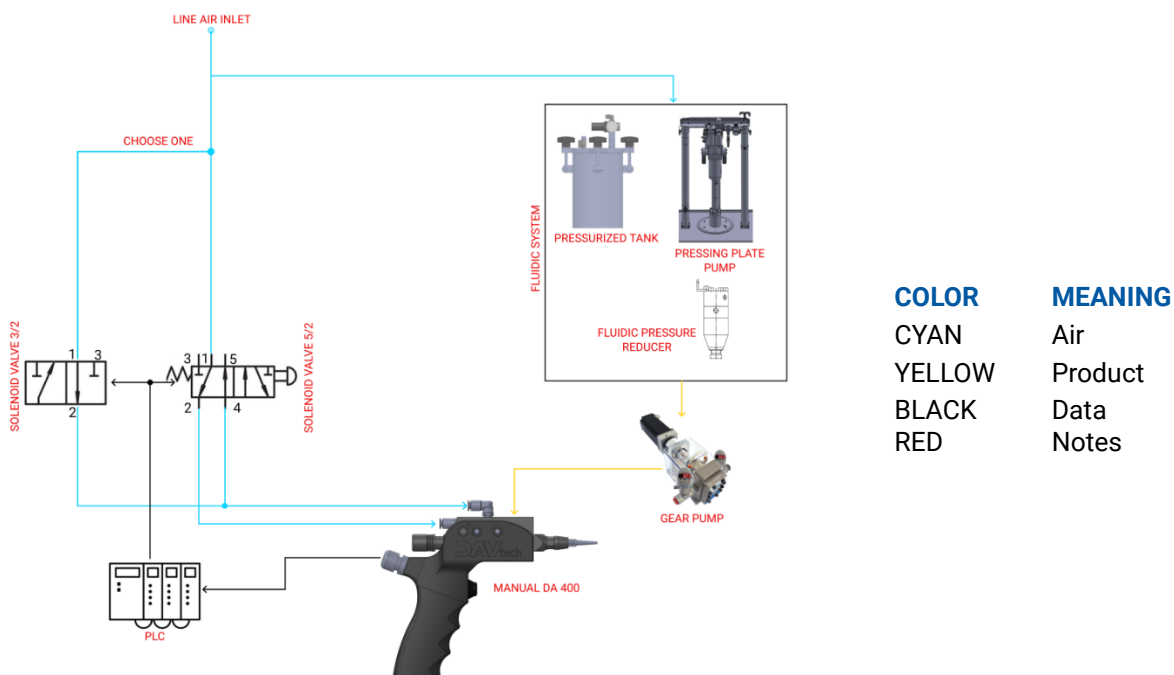

Figure 06 – Connection examples



ATTENTION!

The air entering the valve must be filtered and without water (dried), otherwise it risks forming oxide inside the component and wearing it out more quickly.

2.1 Exploded

The following is a list of the main valve components with spare part numbers.

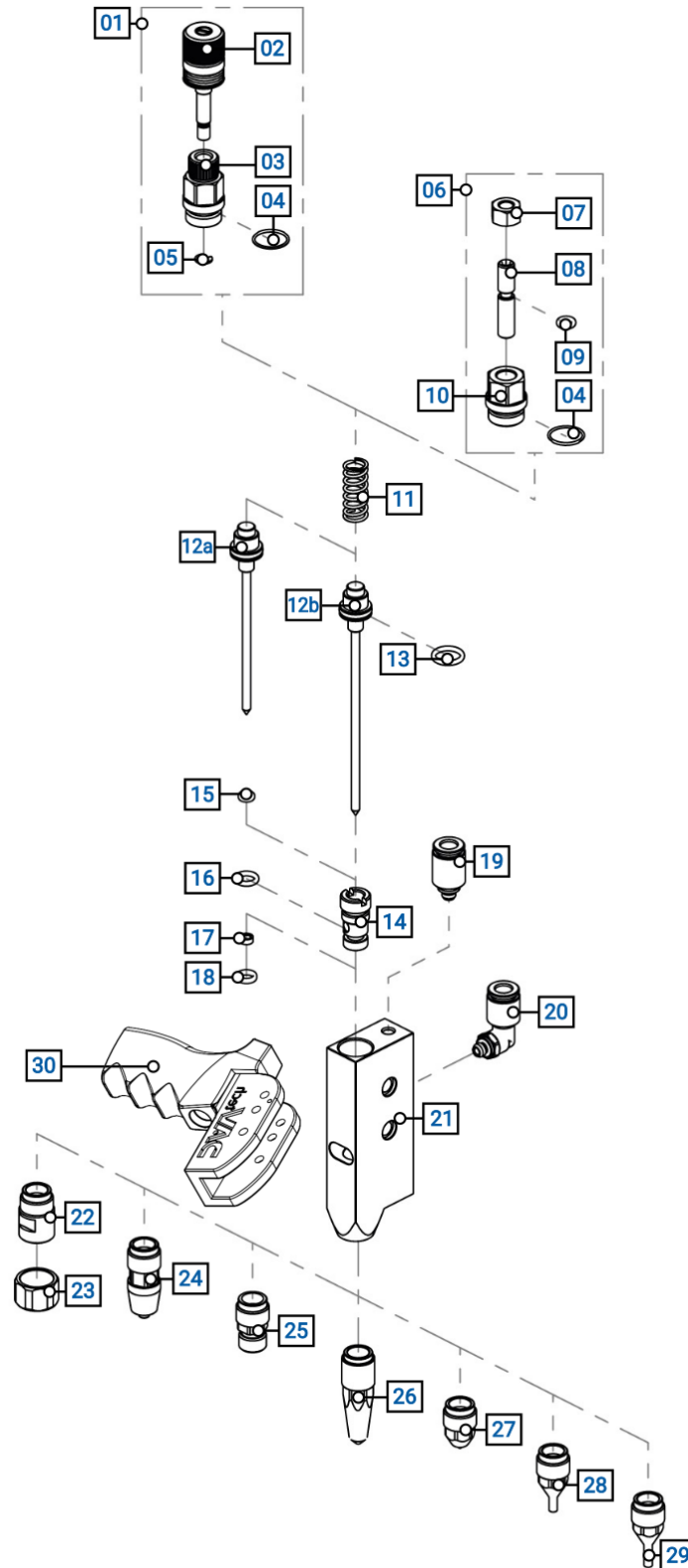

No.	Description	Var.	Code	Variant details
01	FULL MICROMETRIC ADJUSTMENT	-	0003.32500007	-
02	MICROMETRIC ADJUSTMENT KNOB	-	0003.32500008	-
03	MICROMETRIC ADJUSTMENT LOCK	-	0003.32500009	-
04	O-RING	-	0003.100X10E	-
05	SEEGER ADJUSTMENT		0003.200321	
06	FULL SCREW ADJUSTMENT		0003.32500002	
07	SCREW ADJUSTMENT NUT		0003.0006010	
08	GRUB SCREW ADJUSTMENT		0003.32500003	
09	O-RING		0003.000007E	
10	SCREW ADJUSTMENT LOCK		0003.32500004	
11	SPRING		0003.000400	
12a	KV PIN		0003.84230103	
12b	LV-PIN		0003.84230203	
13	O-RING		0003.000011E	
14	COLLET		0003.83100104	
15	O-RING		0003.000006E	
16	O-RING		0003.000010E	
17	SCRAPER		0003.30790T	
18	O-RING		0003.000008E	
19	STRAIGHT AIR FITTING		0003RRAZ0252	
20	90° AIR CONNECTION		0003.RRBF0252	
21	VALVE BODY		0003.000050C	
22	MG 400 NOZZLE		0003.85800101	
23	400 MG NOZZLE RING		0003.85800102	
24	LUER LOCK NOZZLE		0003.85100150	
25	1/8" M NOZZLE		0003.85100180	
26	LV NOZZLE			
		26.a	0003.85310003	LV 0,3 mm NOZZLE
		26.b	0003.85310005	LV 0,5 mm NOZZLE
		26.c	0003.85310008	LV 0,8 mm NOZZLE
		26.d	0003.85310010	LV 1,0 mm NOZZLE
		26.e	0003.85310015	LV 1,5 mm NOZZLE
27	KV NOZZLE			
		27.a	0003.85510003	KV 0,3 mm NOZZLE
		27.b	0003.85510005	KV 0,5 mm NOZZLE
		27.c	0003.85510008	KV 0,8 mm NOZZLE
		27.d	0003.85510010	KV 1,0 mm NOZZLE
		27.e	0003.85510015	KV 1,5 mm NOZZLE
28	KL 7mm NOZZLE			
		28.a	0003.85510105	0.5 mm NOZZLE
		28.b	0003.85510108	0.8 mm NOZZLE
		28.c	0003.85510110	1.0 mm NOZZLE
		28.d	0003.85510115	1.5 mm NOZZLE
29	KL 10mm NOZZLE			
		29.a	0003.85510205	0.5 mm NOZZLE
		29.b	0003.85510208	0.8 mm NOZZLE
		29.c	0003.85510210	1.0 mm NOZZLE
		29.d	0003.85510215	1.5 mm NOZZLE
30	DA-400 HANDLE	-	280720500000	-
\	COMPLETE GASKET KIT		GASKETKIT-DA400-DA400EV	

2.2 Technical data

All the technical characteristics concerning the component of this manual are indicated below.

SPECIFICATIONS		
Description	UdM	Values
Model	\	DA 400
Activation	\	Single or Double Acting
Maximum fluid pressure	bar	25 (single acting)
		80 (double acting)
Minimum air pressure	bar	5
Step per micrometer shot	mm/click	0.008
Pin lift every 360° micrometric	mm	0.5
Air inlet thread	\	M5
Fluid inlet thread	\	1/8 GAS
Fluid outlet thread	\	Threaded nozzle 1/8" GAS
		Nozzle with ring nut (MG)
		Luer lock needle holder
		Steel nozzles of various shapes and sizes (LV and KV)
Maximum control frequency	cycles/min	200
Passage adjustment	\	Micrometric
		Set Screw and Lock Nut (NR)
Materials used	\	Stainless steel
		Widia
		Nickel-plated and Teflon-coated brass



ATTENTION!

Even if the valve is used in double-acting mode, when the air is removed from the system, the fluid pressure must not exceed that indicated in the single effect, otherwise there will be leaks.

ENVIRONMENTAL CHARACTERISTICS

Description	UdM	Values
Working Ambient Temperature	°C	5 ÷ 45
Storage Ambient Temperature	°C	-20 ÷ 55
Permissible non-condensing humidity	%	5 ÷ 90

USABLE FLUIDS

Silicones

Liquid gaskets

Oil

Grease

Resins

Various medium-high viscosity products (contact the manufacturer for more information)

DIMENSIONAL AND WEIGHT CHARACTERISTICS

Description	UdM	Value
Component length (min ÷ max)	mm	187.4
Component depth (min ÷ max)	mm	31.75
Component height (min ÷ max)	mm	151.15
Component weight	kg	0.5

Component

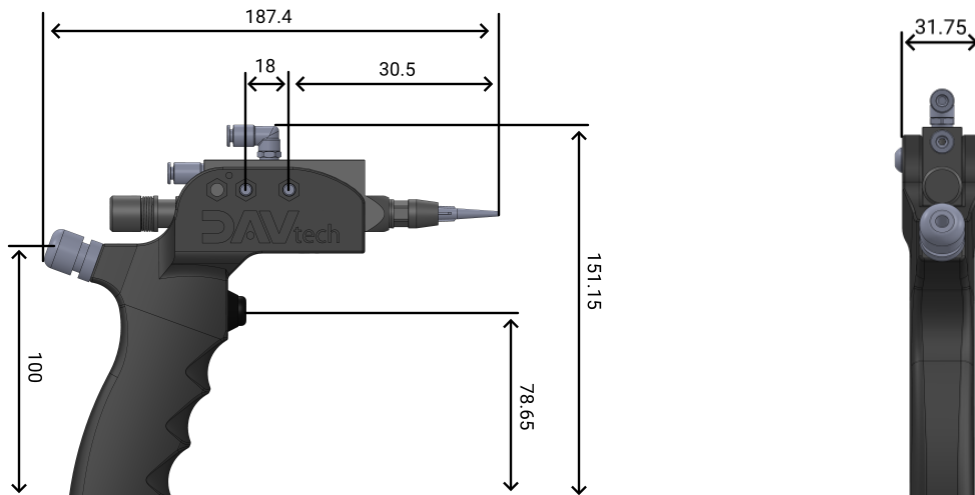

You can request the 3D of the component in the desired version from the manufacturer without any obligation.

3 SAFETY

The following is a list of warnings regarding the component covered by this manual. Please read carefully before proceeding to the next chapters.



DANGER!

Before operating the component or performing any action on it, read this manual carefully.



DANGER!

Do not use the component while under the influence of drugs or other substances that may impair attention and reaction ability.



DANGER!

Operators must only perform operations or interventions that are within the competence of the role and qualification assigned.



FIRE/EXPLOSION HAZARD!

This component is not designed to work in an ATEX environment.



DANGER!

Be very careful when servicing the component, especially when disassembling components that have pressure springs inside.



ATTENTION!

Modifications to the component must not be made to achieve performance other than that for which it was designed and built, unless authorized by the manufacturer.



ATTENTION!

Avoid introducing foreign bodies, even small ones, into the pneumatic system, which could cause the system to malfunction and compromise the safety of the machine.



The component may only be used by trained and authorized operators and for the sole purpose for which it was designed and manufactured.



The component is manufactured in compliance with the technical safety standards in force at the time of its construction.

3.1 Component safety devices

N.A.

3.2 Free useful spaces

N.A.

3.3 Risk areas and residual risk

There are the following residual risks on the component:

- **Dangers due to electricity:** the passage of pressurized fluid generates static electricity which, if touched by personnel who are not properly isolated, can be dangerous;
- **Hazards due to inhalation of hazardous vapors:** The component is not designed to have insulation from any toxic and/or hazardous vapors; personnel working with this device should be aware of this during its use;
- **Fire hazard due to vapors:** Personnel working near this component must absolutely not have any heat sources that could start a fire;
- **Risk due to fluid projection under pressure:** Due to incorrect maintenance of the component, it can lead to the expulsion of some parts of the component and consequent expulsion of fluid.

4 TRANSPORT AND HANDLING

Once you have received the goods, you must check that the packaging is intact and that there is an exact correspondence with the material ordered.



ATTENTION!

The original configuration of the component must not be changed. The manufacturer is not liable for damage caused by inappropriate use of the component.



ATTENTION!

If the packaging is not intact, contact the manufacturer immediately, also sending photos of the condition of the packaging. Do not open it until you have notified the manufacturer.

5 INSTALLATION



The installation of the component is carried out by the customer. If necessary, you can contact the manufacturer to have a specialist technician help you.

The valve has been designed to be used in the following cases:

- Work independently as a fluid dispenser on a pressure/time basis;
- Work in tandem with a GP volumetric gear pump to dose the fluid in a volumetric way.

It is also equipped with two calibrated seats (number 04, figure 01, [chapter 2](#)) to have perfect centering both during installation and during maintenance. It is also advisable to fix it well to the support, as the vibrations that are caused by the machinery in operation could take the valve off-center, resulting in a dosage that is not optimal.



It is recommended that you perform a component check before beginning the installation. If it is evidently damaged, please contact the manufacturer.



ATTENTION!

Please remove the packaging with the utmost care. If damage is caused to the component, the manufacturer is not liable.



Dispose of the packaging correctly, considering the different nature of the components and following the regulations in force in the country.

5.1 Positioning







N.A.

5.2 Connections

In this chapter, we want to explain the connection method that must be used for the component. The following types of connection are provided:

- Electrical connection;
- Pneumatic connection;







5.2.1 Electric

Authorized personnel	 PPE to wear					
Component status	PLC installed, with outgoing communication cable					
Power Values	See chapter 2.2					
Necessary preparations	Electrical cable with correct power supply					
Materials needed	N.A.					
Equipment needed	N.A.					

 The electricity connection is at the expense of the customer.

The only point to be connected is the button, which must be connected to the control system in use (control unit or PLC). The connector is three-pole and has a 24VDC power supply.

5.2.2 Pneumatic

Authorized personnel	 PPE to wear					
Component status	Component installed					
Power Values	See chapter 2.2					
Necessary preparations	Working pneumatic air system					
Materials needed	Fixing screws (for centering holes)					
Equipment needed	Wrench or screwdriver					

 The pneumatic connection is the responsibility of the customer.

Before assembling the valve, it is recommended to calibrate it, to perform it precisely and once performed, you can proceed with the assembly and possible fixing by screws passing through the centering holes. For connections, it is recommended to connect the pneumatic hose first (or both in the case of double-acting work) and then proceed with the connection of the product hose (using the data given in [chapter 2.2](#)).

5.3 Commissioning

The commissioning of the component is carried out once the positioning and connection of the connections has been completed. Before commissioning the component, the following checks must be carried out:

- Check that the connections have been connected correctly;
- Check that the component is free of dirt or residues of various kinds;



ATTENTION!

If even one of the above points does not comply, commissioning must not be carried out. Commissioning should only be carried out when all points have been successfully completed.

6 SOFTWARE

N.A.

7 PROCEDURE

In this chapter we want to explain the main configurations that can be used on the component covered by this manual. In particular, we want to explain in detail:

- How to perform the needle adjustment, both with the screw and micrometric configuration;

It should be noted that the output fluid does not depend only on the needle adjustment, but also on other factors, namely:

- **Nozzle diameter:** the larger the nozzle diameter, the higher the flow rate of fluid at the outlet;
- **Fluid pressure:** the higher the fluid pressure, the higher its outlet flow rate;
- **Needle stroke adjustment:** The larger the needle stroke, the higher the flow rate.

7.1 Screw adjustment

To perform the needle adjustment by screw, the screw must be adjusted. In particular, you must:

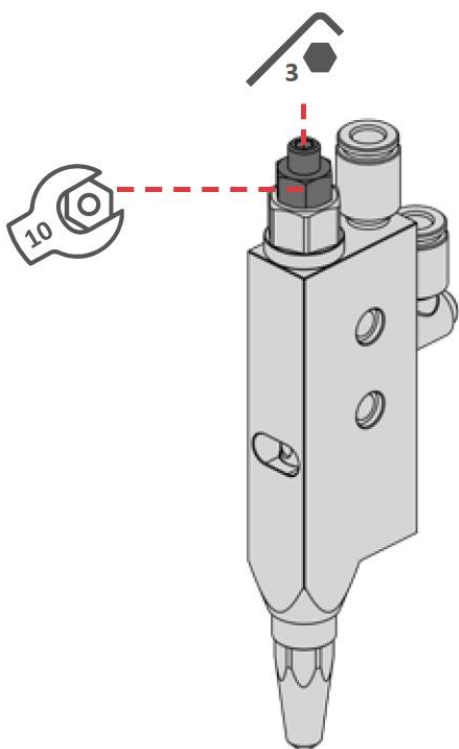

1. Unscrew the nut with a 10 wrench while holding the grub screw in place with a 3 Allen key;
2. Holding the nut in place, you must:
 - a. Turn the grub screw counterclockwise to increase the pin stroke. By doing so, the outgoing fluid is increased;
 - b. Turn the grub screw clockwise to decrease the pin stroke. By doing so, the outgoing fluid is decreased.
3. Finally, the nut must be closed while holding the adjusting grub screw in place, so as to block the grub screw and prevent it from going out of calibration.



ATTENTION!

The needle adjustment should not be tightened too tightly to avoid damaging the nozzle and needle.

7.2 Micrometric adjustment

In this case, the adjustment knob must be adjusted (see [chapter 2](#), figure 01, number 01), to adjust the amount of fluid dispensed with extreme precision, namely:

- Turn counterclockwise to increase the needle stroke and therefore the amount of fluid dispensed;
- Turn clockwise to decrease the needle stroke and therefore the amount of fluid dispensed. If you reach the end of the stroke, the valve is completely closed and, therefore, there is no fluid delivery.

8 MAINTENANCE

Maintenance interventions are all those activities that must be performed on the component which, if carried out correctly, allows it to have a longer life. In general, maintenance is divided into two groups:

- **Ordinary maintenance**, which are interventions on a regular basis or that can be carried out by the customer's staff, are the most important activities as they allow the component to be kept in good working condition;



ATTENTION!

Ordinary maintenance must be carried out in the manner and timing indicated in the following chapters.

- **Extraordinary maintenance**, i.e. all those interventions that are not regularly carried out or that have not been planned, or interventions that cannot be carried out by the Customer. They can also arise from the lack of routine maintenance.



ATTENTION!

Extraordinary maintenance work must be carried out together with the manufacturer's specialized technicians.



Regarding attendance, it must be considered that:

- **When necessary:** Operation to be carried out when the need to be carried out is seen;
- **Every machine start or job end:** Indicates a daily period, in general. This can imply every 24 hours (i.e. at the beginning of the shift of every day, or the end of the shift of every day), or even more frequently, depending on the application;
- **Long pause:** Indicates a period approximately greater than an hour;
- **Each drum change:** Indicates each time the fuel system (tank, drum, cartridge or other) is changed;
- **Each mixer disassembly:** Indicates that each time the mixer is replaced, a certain operation must be performed;
- **Weekly:** Indicates a period equal to seven calendar days;
- **Monthly:** Indicates a period equal to one calendar month;
- **Semi-annual:** Indicates a period equal to six calendar months;
- **Yearly:** Indicates a period equal to one calendar year.



ATTENTION!

The times given below are indicative as they depend on how the component is used. Follow the variations suggested by the technicians.

Assigned	Description	Frequency	Chapter
	Perform a test function of the valve	Every machine start-up or end of work	\
	Perform a surface cleaning of the valve	Every machine start-up or end of work	\
	Cleaning and/or replacing the nozzle	Semiannual	8.1
	Disassembly and reassembly of the valve	Annual	8.1



ATTENTION!

Use the necessary precautions if you use products that in contact with the air cross-link



ATTENTION!

Only use soft brushes or cotton cloths to clean the valve.

8.1 Disassembly and reassembly of the valve

Assigned	Periodicity	Materials and equipment
	Annual	<ul style="list-style-type: none"> • Key of 10 and 13; • 3mm hex screw; • Narrow-nose pliers; • Phillips screwdriver PH1; • Slotted screwdriver 1.6x10.

PPE to wear



ATTENTION!

Before performing this procedure, you must relieve the pressure from the system and disconnect the air connection.

The disassembly and assembly procedure is the same as that of the DA 400 valve. To remove the gun, remove the screws that hold the valve to the gun itself, positioned in point 09 figure 01 [chap. 2](#) and remove the valve from the gun itself.

01



Unscrew the air fittings using an Allen wrench of the following dimensions:

- 2.5 for fitting number 02 Figure 01 [Chapter 2](#);
- 3 For fitting number 03 Figure 01 [Chapter 2](#).

02

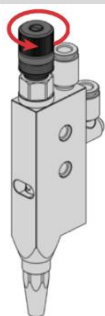

Unscrew the needle adjustment using the appropriate adjustment nut (or micrometric valve) until there is no more resistance

03

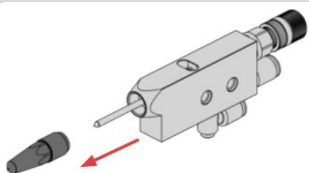

Unscrew the nozzle with a wrench of 10.

Once the nozzle has been disassembled, a simple cloth can be used to clean it. If the hole is obstructed, it must be freed from occlusion



Points 02 and 03 are used to disassemble the outlet nozzle only. To reassemble it, follow the reverse procedure.

04

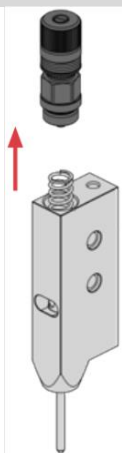

Unscrew the adjustment lock with a wrench of 13



ATTENTION!

Under this block there is a spring that is in compression. Unscrew it paying close attention.

05

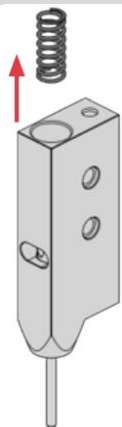

Sweep the spring

06



Remove the pin with the help of narrow-nosed pliers



07



Unscrew the sleeve with a 1.6x10 slotted screwdriver and remove it from the valve body.

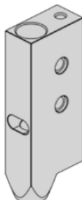

08



Check the wear and condition of the components in positions 15, 16, 17 and 18 of [chapter 2.1](#) and replace them if necessary. In any case, always lubricate the components before reassembling them with grease or silicone-based oil specifically designed for o-rings.

To reassemble the valve, follow the same steps just seen but in reverse. Before starting the assembly phase, always clean the components, check the o-rings for wear (replace them if necessary) and always lubricate the o-rings.



ATTENTION!

When installing the micrometer regulator or clamping screw, pay particular attention that the thread is inserted correctly, i.e. perpendicular to the body, and not that it is inclined.



ATTENTION!

Before screwing the nozzle into place, check that the adjusting screw, or knob, is completely loose to avoid damaging the nozzle and needle. To loosen them, turn counterclockwise until they no longer resist.

9 TROUBLESHOOTING

This chapter deals with the most common problems that may arise when using the component of this manual.



ATTENTION!

Once the operator has found a problem or assumes that there is a problem, they must call the technician in charge of maintenance. Maintenance should always be performed by a specialized and qualified technician.

DEFECT	CAUSE	SOLUTION
Low fluid output or no fluid	The valve does not receive the command	Check the valve control (solenoid valve). Perform a manual test
	Fluid pressure is too low or no fluid	Check the pressure of the fluid supply unit and increase it if necessary
	The nozzle is clogged	Unscrew and clean the nozzle
	The filter is dirty (if any)	Wash or replace the filter
	A tube is kinked	Check the condition of the fluid supply hoses
	Insufficient operating pressure	Check the actuation pressure (chap. 2.2)
Fluid leaking from the compass	Fluid residues present in the system	Disassemble and clean any solid particles
	Damaged scraper	Replace the scraper
Nozzle drips even if valve is not piloted	Damaged pin	Replace the pin
	Dirt in the nozzle	Clean or replace the nozzle
Valve opens late	Insufficient operating pressure	Check the actuation pressure (chap. 2.2)
	O-Ring on Damaged Air Piston	Replace O-Ring on Pneumatic Piston
You press the button but it does not perform the dosage	The button does not work properly	Check electrical connections and cable integrity

10 END OF LIFE

End-of-life refers to all those activities that put the component out of service. End-of-life activities can be:

- **Storage**, i.e. when the component is placed inside the warehouse for an unspecified period waiting for a third party to buy the component;
- **Dismantling**, i.e. when the component has reached the end of work period, whether it is due to age, obsolescence or faults that cannot be repaired, or that it is possible to repair but it is worth buying a new component.

If installation is not planned soon, the component can remain packaged and must be stored in a sheltered and preferably closed place. The ambient temperatures to be observed are given in [chapter 2.2](#).

On the other hand, for the dismantling and consequent scraping of the component or its parts, the different nature of the various components must be considered, and a differentiated scrapping must be carried out. We recommend that you commission specialist companies for this purpose and must always observe the applicable laws on waste disposal.