

USE AND MAINTENANCE MANUAL

E2K – 200 AND E2K – 400 EXTRUSION SYSTEM



Summary

- 1 GENERAL INFORMATION..... 1**
 - 1.1 SYMBOLOGY..... 2
 - 1.2 REFERENCE STANDARDS 3
 - 1.3 DECLARATION OF INCORPORATION (ANNEX II B DIR. 2006/42/EC) 4
 - 1.4 GLOSSARY..... 5
 - 1.5 SERVICE AND MANUFACTURER CONTACT DETAILS 6
- 2 PRESENTATION AND OPERATION 7**
 - 2.1 EXPLODED..... 10
 - 2.2 TECHNICAL DATA 12
- 3 SAFETY 13**
 - 3.1 MACHINE SAFETY DEVICES..... 14
 - 3.2 FREE USEFUL SPACES 14
 - 3.3 RISK AREAS AND RESIDUAL RISK 14
- 4 TRANSPORT AND HANDLING..... 14**
- 5 INSTALLATION 15**
 - 5.1 POSITIONING..... 15
 - 5.2 CONNECTIONS..... 15
 - 5.2.1 *Electric*..... 16
 - 5.3 COMMISSIONING..... 17
- 6 SOFTWARE..... 17**
- 7 PROCEDURE 17**
 - 7.1 CARTRIDGE CHANGE..... 18
 - 7.2 INSTALLATION OF THE MIXER CLOSING BRACKET..... 18
 - 7.3 HEIGHT ADJUSTMENTS..... 19
- 8 MAINTENANCE 20**
- 9 TROUBLESHOOTING..... 21**
- 10 END OF LIFE..... 21**

1 GENERAL INFORMATION

This manual contains information regarding the installation, use, maintenance and end of life of the component and provides indications for the most suitable behavior for correct operation. This manual has been designed to be simple and as straightforward as possible, with a subdivision into chapters and sub-chapters that allows you to find any information you need quickly. In addition, the manual begins by giving a general description of the contents, then an overview of the component, to arrive at aspects of safety, transport, installation and use and finally to the end of life. If you have any doubts about the interpretation or reading of this document, please contact the manufacturer.



DAV Tech declines any responsibility relating to improper use of the component. Observe the specifications in this manual.



Read this manual before handling the component or performing any action on it.



The manual is an essential safety requirement and must accompany the component throughout its life cycle.

It is the task of the end user to optimize the functionality of the component, always considering the purpose for which it was built.



You are asked to keep this manual, together with the attached documentation, in good condition, legible and complete. In addition, it must be stored in the vicinity of the component or, in any case, in a place accessible and known to all personnel who use the component itself or who must perform maintenance or inspection interventions. If the manual deteriorates or is no longer complete, a copy must be requested from the manufacturer, indicating the code of the manual and the revision.



The manual is intended for personnel who use the component (operators), who perform maintenance on it (maintenance technicians), and for personnel who must perform checks or inspections. The manufacturer is not liable for damage to the component caused by personnel who have not followed the instructions in the manual.

If you have any doubts about the correct interpretation of the information contained in this manual, please contact the manufacturer.

GUARANTEE

During the design phase, a careful choice of materials and components to be used in the project was made and they were subjected to regular testing before delivery. All elements have been designed and manufactured with an adequate degree of safety, such as to be able to withstand stresses greater than those of normal use.

The warranty is valid for a period of 12 months from the date of commissioning and in any case no longer than 15 months from the date of delivery. Work carried out during the warranty period does not extend the warranty period in any way.

The manufacturer is not liable for defects due to normal wear and tear of parts which, by their nature, decay.

1.1 Symbology

Below are the symbols that are used to give a greater impact to the importance of the concept you want to give.



ATTENTION!

Refers to a warning that could lead to minor damage (minor injuries, damage to the component requiring maintenance work).



DANGER!

It refers to a major event that could cause major damage (death, permanent injury, irreversible breakage of the component).



NOTE. Indicate relevant information or insight.



OBLIGATION. It indicates a task that must be performed, related to both the component and the manual.



REFERENCE. Links to an external document that is important to view

In addition, the list of symbols is integrated with that of the personnel responsible for using the component and its function, together with other symbols used within the manual.



Operator

A (qualified) person capable of operating the component, adjusting, cleaning, starting or resetting the component. The operator is not authorized to perform maintenance.



Mechanical maintenance technician

Qualified technician able to carry out mechanical, adjustment, maintenance and routine repair work described in this manual. He is not authorized to carry out interventions on electrical systems in the presence of voltage.



Electrical maintenance technician

Qualified technician able to carry out electrical, adjustment, maintenance and routine repair work described in this manual. It can work in the presence of voltage on electrical cabinets and junction boxes. He is not authorized to carry out interventions on the mechanical side.



Manufacturer's technician

Qualified technician made available by the manufacturer to carry out operations of a complex nature in particular situations, or in any case as agreed with the customer.

1.2 Reference standards

The reference standards and directives of this manual are the following:

Directives

- 2006/42/EC – Machinery Directive;

1.3 Declaration of incorporation (Annex II B DIR. 2006/42/EC)

Manufacturer's name: DAV Tech Srl
Address: Via G. Ravizza, 30, .36075, Montecchio Maggiore (VI)

DECLARES THAT THE ALMOST MACHINE

Component: E2K – 200; E2K – 400
Model: 200ml and 400ml extrusion system
Year: 2024
Intended use: Volumetric dosing of two-component fluid using the extrusion method

COMPLIES WITH THE INCORPORATION PROVISIONS OF DIRECTIVE 2006/42/EC

The technical documentation has been drawn up in accordance with Annex VII B, as required by the following:

- Machinery Directive 2006/42/EC of the European Parliament and Council of 17 May 2006

IT ALSO DECLARES THAT:

- Undertakings are undertaken to provide, in response to a properly substantiated request from the national authorities, relevant information on this partly completed machine;
- The technical file was prepared by Andrea Grazioli, via Ravizza, 30, Montecchio Maggiore (VI), IT.

This quasi-machine cannot be used until the machinery on which it will be used is declared compliant with regulation 2006/42/EC.

Montecchio Maggiore, 22 August 2024

The legal representative

Andrea Grazioli

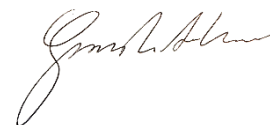

1.4 Glossary

The following are the most used terms within this manual with their meanings.

TERM	DEFINITION
Enable	Term that defines the act of preparing (enabling) an action. The action will be triggered as soon as the criteria are met, which consequently leads to the activation of the enabled action.
Active	The action that is performed instantaneously when the control is activated.
Human controls	This defines those commands that, used for manual operations, must be kept activated for the action to be performed. When the command is released, the action stops.
Two-hand controls	Human-controlled controls that require two manual controls to be operated simultaneously to perform an action.
P.P.E.	Personal protective equipment. They include all the items necessary to ensure the protection of personnel from possible accidental damage (safety shoes, gloves, helmet, and more).
Display	It is used to display information. It can be in any shape and size, even touch screen.
Manufacturer	Natural or legal person who designed and manufactured the component covered by this manual.
Icon	A small image that represents a command, a function or even a document or an operating program, which appears on a computer screen. When selected by the user, it initiates the function or program it symbolizes.
Joystick	Lever manipulator used in control panels.
N.A.	Not Applicable, i.e. it indicates that it is a field that does not apply to this manual and that it cannot be integrated into the component.
Operator panel	A control station where the machine control instruments are located
P.I.	Possible Implementation, i.e. it is currently absent from the component described in this manual, but it is possible to make an addition and implement it.
Screen	Interface system between man and component. Screenshots are the images displayed on the operator panel that allow the user to receive and provide information to the management software.
Push-button panel	Composition of buttons and selectors that allow you to act directly on the behavior of the component.
Keyboard	Keyboard only (stand-alone element) or in addition to a display (keys only, no selectors or other)
Touch screen	Touch screen that allows the user to interact with a graphic interface using their fingers or objects.

1.5 Service and manufacturer contact details

For any reason relating to the use, maintenance or request of spare parts, the customer must contact the manufacturer (or the service center if present) directly, specifying the identification data of the component.

The customer can make use of the technical and commercial support of local agents or importers, who are in direct contact with the company DAV Tech Srl.

Company name	DAV Tech Srl
Postal address	Via Ravizza, 30, 37065, Montecchio Maggiore (VI) – (IT)
Telephone	+39 0444 574510
Fax	+39 0444 574324
email	davtech@davtech.it
Website	www.davtech.it

2 PRESENTATION AND OPERATION

This dosing system is based on extrusion, i.e. two pistons push at the same time inside two separate cartridges so that the fluid, by pressure, comes out of the nozzle, mixing with the correct doses, according to the customer's needs. To work, this system only needs to power the electric motor located on the back of the system, since the fluid to be dosed is already inside the component itself.

In other words, the function of this component is:

TWO-COMPONENT FLUID DISPENSING BY EXTRUSION

Intended use is the use described in the chapter below, while improper use is considered any other use that is not described in this manual, with products of different material and format from those for which it was built.

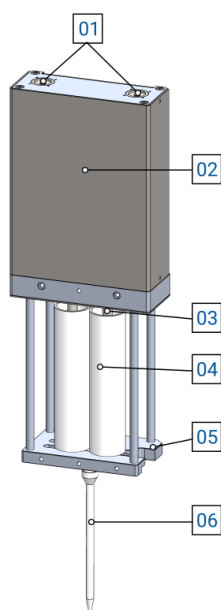

No.	DESCRIPTION
01	Engine transmission
02	Central body
03	Pistons
04	Cartridge
05	Cartridge attachment
06	Mixer

Figure 01 – E2K – 400 Detail

Before using a certain type of fluid, it is necessary to check that:

- The viscosity of the fluid is compatible with the characteristics of the system;
- The characteristics of the fluid meet the desired requirements;
- The technical data sheet of the fluid provided by the manufacturer contains all the information regarding the product such as viscosity, applications, drying times and storage;
- The fluid storage time has not been exceeded;
- The fluid packages are tightly sealed.

SPECIAL VERSIONS

This extrusion system has an additional component (on customer request) which is the mixer closing valve assembly (code 180923032227D). The component has the function of interrupting the dosage when the suction is not sufficient, such as in the case of very fluid products.

A 5/2 solenoid valve controls the opening and closing of a 2/2 ball valve mounted on the mixer closing support

The pneumatic connection is made via two 4x2.5 pipes. The nozzle support is tailor-made, based on the type of application required by the customer's product, with pressure between 5 ÷ 7 bar.

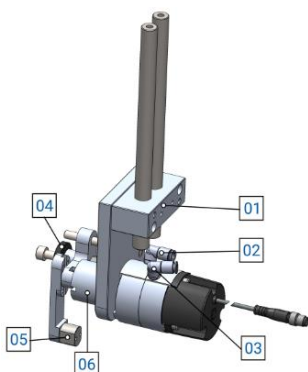

No.	DESCRIPTION
01	Body Attachment Bracket
02	Valve closure
03	Valve opening
04	Spacer spring
05	Dosing nozzle support
06	Closing body

OPERATION

The component is started by electronic impulse from the control system, which can be a PLC or a controller, which starts the motor. From here, through a transmission system, two worm screws are set in motion, which raise or lower the thrust block that is connected to the pistons that are inserted directly inside the cartridge. If these lower, the cartridge pushes the product out (from both cartridges), volumetrically dosing the product. If the pistons rise, they return to rest to relieve the pressure after dosing, or to release the cartridge and perform the cartridge change.

You can also have cartridges that have different ratios: in this case, the piston body is adapted to the size of the cartridge holes, just indicate it to the manufacturer. If spare parts are needed, the correct ratio must also be indicated to the manufacturer.

Figure 02 shows the most complete case. For minimum working pressures, please refer to [Chapter 2.2](#).

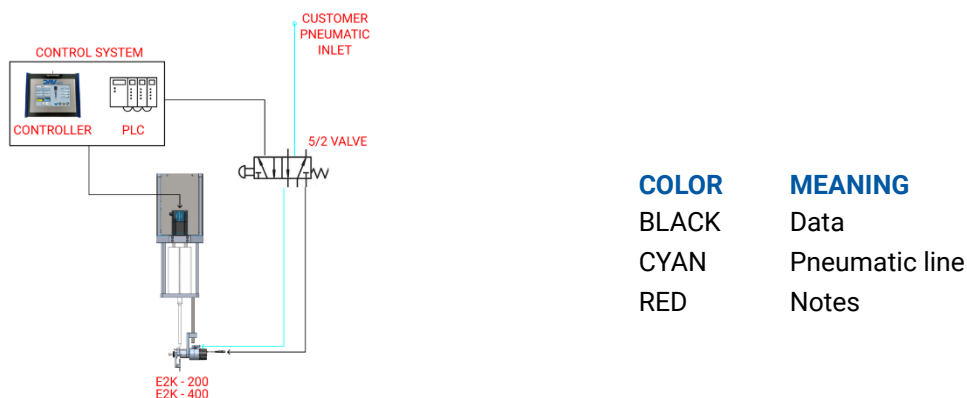
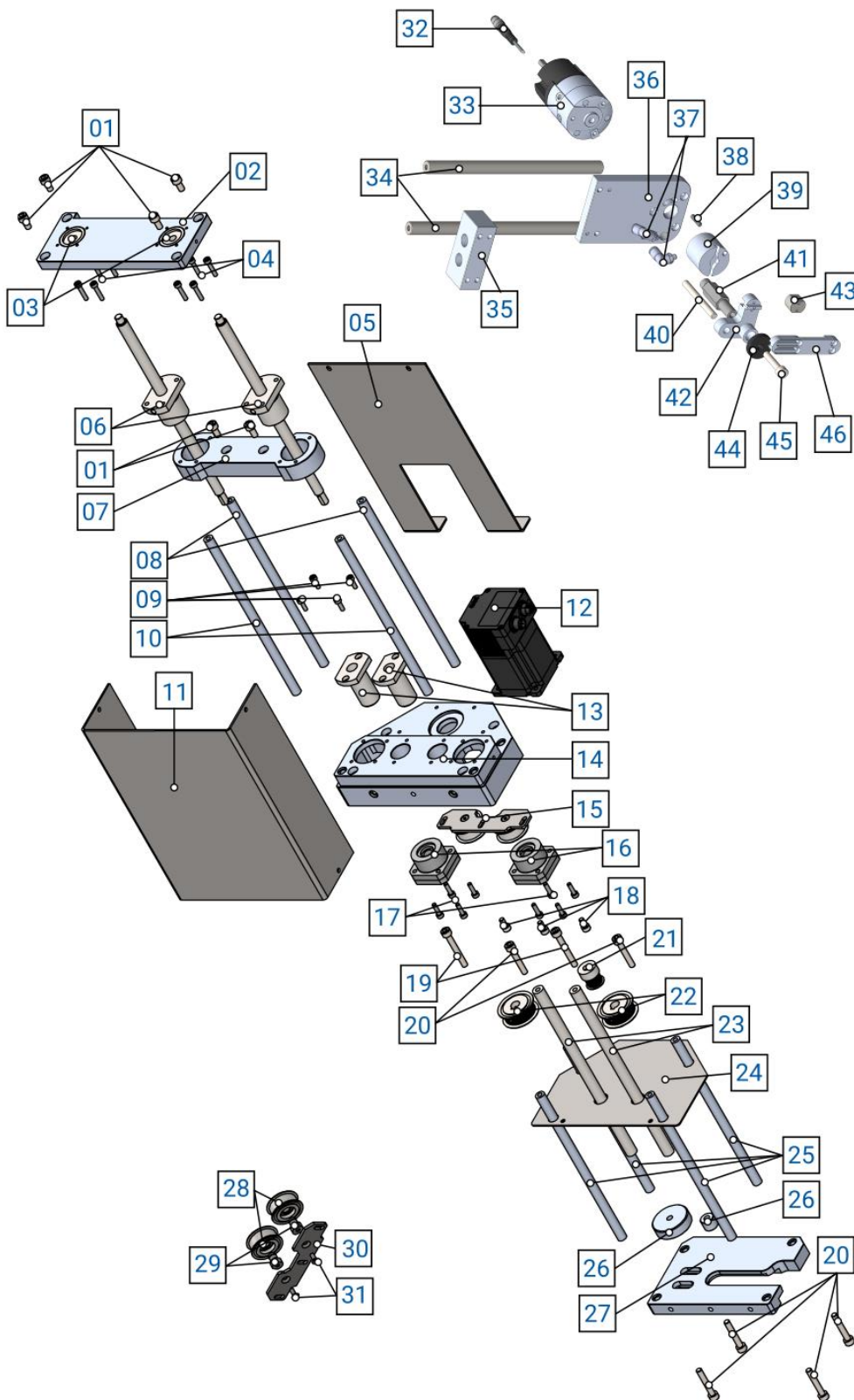

Figure 02 – Connection Example

2.1 Exploded

The following is a list of the main valve components with spare part numbers.



No.	Description	Var.	Code	Variant details
01	SCREW SHCS M6X12	-	SHCSM6X12	-
02	SCREW SUPPORT PLATE	-	210420570000	-
03	BEARINGS	-	_C-BUR10_b	-
04	SCREW SHCS M4X20	-	SHCSM4X20	-
05	REAR CRANKCASE	-	210420520000	-
06	WORM SCREW	-	FBSSZBN1204-270-F15-P8-S30-V10-U10-SC13-G8-Q8	-
07	PUSH PLATE	-	210420550000	-
08	UPPER TIE	-	-	-
09	SCREW SHCS M4X10	-	SHCSM4X10	-
10	FRONT UPPER TIE ROD	-	-	-
11	FRONT CASING	-	210420510000	-
12	ELECTRIC MOTOR	-	M60SH65-T00512P24C_M90	-
13	WORM SCREW LOCK	-	LHFCDM12	-
14	TRANSMISSION LOCK	-	210420550000	-
15	TURNBUCKLE	-	210420590000	-
16	WORM BLOCK SEALING	-	BRW10-SET	-
17	SCREW SHCS M4X12	-	SHCSM4X12	-
18	SCREW SHCS M5X10	-	SHCSM5X10	-
19	SCREW SHCS M6X45	-	SHCSM6X45	-
20	SCREW SHCS M6X35	-	SHCSM6X35	-
21	TRANSMISSION	-	_HTPS18S3M100-K-P8_b	-
22	TRANSMISSION	-	_HTPM36S3M100-A-NK10_b	-
23	CHROME BAR ⁽¹⁾	-	-	-
24	TRANSMISSION COVER	-	210420530000	-
25	STRAP	-	-	-
26	PAIR PADS 10:1 ⁽¹⁾	-	210420630000	-
27	CARTRIDGE GUIDE PLATE	-	210420540000	-
28	BEARINGS	-	BDF15-30	-
29	NUT	-	FXHA8-6-F6	-
30	TENSIONER PLATE	-	210420600000	-
31	M4X10 SCREWS	-	SK-ISK DIN-7991 M4X10-A2	-
32	MOTOR SPEED SENSOR	-	-	-
33	AIR MOTOR	-	-	-
34	CONNECTION EXTENSIONS	-	-	-
35	CONNECTING BODY	-	-	-
36	BACKING PLATE	-	-	-
37	PNEUMATIC CONNECTIONS	-	-	-
38	FIXING PIN	-	-	-
39	VALVE CLOSING BLOCK	-	-	-
40	SPACER SCREW	-	-	-
41	SPACER SUPPORT	-	-	-
42	SPACER LOCK	-	-	-
43	NOZZLE HOLDER	-	-	-
44	SPACER WASHER	-	-	-
45	DISTANCE ADJUSTMENT SCREW	-	-	-
46	NOZZLE HOLDER REGULATOR LOCK	-	-	-

⁽¹⁾ The characteristics of these components may vary according to the dosage ratio required by the application. In addition, they may vary depending on the extruder model used (E2K-200 and E2K-400) Ask the manufacturer's technicians for more information.

2.2 Technical data

All the technical characteristics concerning the component of this manual are indicated below.

SPECIFICATIONS		
Description	UdM	Values
Model	\	E2K – 400
Activation	\	Electronic
Motor power supply	VDC	24
Phase Current	A	2.8
Motor cable type	\	M12 5-pole female
Encoder cable type	\	M12 5-pole male
Passage adjustment	\	N.A.

ENVIRONMENTAL CHARACTERISTICS		
Description	UdM	Values
Working Ambient Temperature	°C	5 ÷ 45
Storage Ambient Temperature	°C	-20 ÷ 55
Permissible non-condensing humidity	%	5 ÷ 90

USABLE FLUIDS
200cc or 400cc 2K cartridges with various ratios (refer to chapter 2 note)

DIMENSIONAL AND WEIGHT CHARACTERISTICS		
Description	UdM	Value
Component length (min ÷ max)	mm	186
Component depth (min ÷ max)	mm	123
Component height (min ÷ max)	mm	490
Component weight	kg	7.5

Component

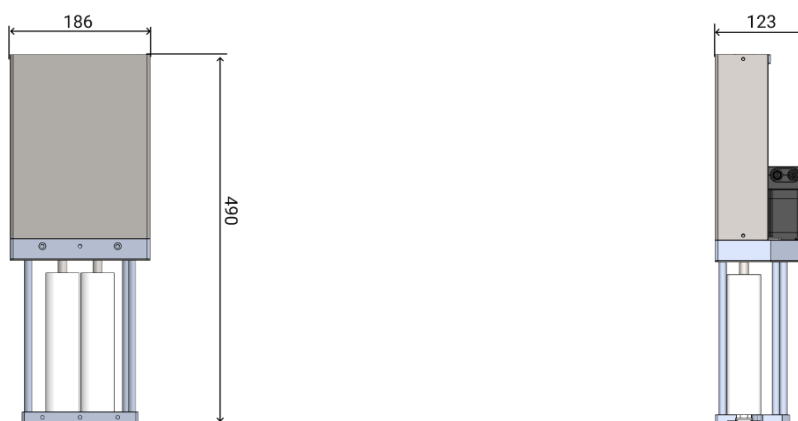

You can request the 3D of the component in the desired version from the manufacturer without any obligation.

3 SAFETY

The following is a list of warnings regarding the component covered by this manual. Please read carefully before proceeding to the next chapters.



DANGER!

Before operating the component or performing any action on it, read this manual carefully.



DANGER!

Do not use the component while under the influence of drugs or other substances that may impair attention and reaction ability.



DANGER!

Operators must only perform operations or interventions that are within the competence of the role and qualification assigned.



FIRE/EXPLOSION HAZARD!

This component is not designed to work in an ATEX environment.



DANGER!

Be very careful when servicing the component, especially when disassembling components that have pressure springs inside.



ATTENTION!

Modifications to the component must not be made to achieve performance other than that for which it was designed and built, unless authorized by the manufacturer.



ATTENTION!

Avoid introducing foreign bodies, even small ones, into the pneumatic system, which could cause the system to malfunction and compromise the safety of the machine.



The component may only be used by trained and authorized operators and for the sole purpose for which it was designed and manufactured.



The component is manufactured in compliance with the technical safety standards in force at the time of its construction.

3.1 Machine safety devices

N.A.

3.2 Free useful spaces

N.A.

3.3 Risk areas and residual risk

N.A.

4 TRANSPORT AND HANDLING

Once you have received the goods, you must check that the packaging is intact and that there is an exact correspondence with the material ordered.



ATTENTION!

The original configuration of the component must not be changed. The manufacturer is not liable for damage caused by inappropriate use of the component.



ATTENTION!

If the packaging is not intact, contact the manufacturer immediately, also sending photos of the condition of the packaging. Do not open it until you have notified the manufacturer.

5 INSTALLATION



The installation of the component is carried out by the customer. If necessary, you can contact the manufacturer to have a specialist technician help you.

This component has been designed as a support for the operation of other components, i.e. it cannot work alone but must be connected to an external power supply, to allow the power supply itself to perform a function that, on its own, it could not perform.

It is equipped with 4 threaded holes for fixing on a bracket, useful both for autonomous operation and for operation on machinery. It is important to secure the component well to its support as otherwise it risks generating vibrations that can affect the operation of the component itself.



It is recommended that you perform a component check before beginning the installation. If it is evidently damaged, please contact the manufacturer.



ATTENTION!

Please remove the packaging with the utmost care. If damage is caused to the component, the manufacturer is not liable.



Dispose of the packaging correctly, considering the different nature of the components and following the regulations in force in the country.

5.1 Positioning

N.A.

5.2 Connections

In this chapter, we want to explain the connection method that must be used for the component. The following types of connection are provided:

- Electrical connection;

5.2.1 Electric

Authorized personnel	PPE to wear
Machine status	PLC installed, with outgoing communication cable
Power Values	See chapter 2.2
Necessary preparations	N.A.
Materials needed	N.A.
Equipment needed	N.A.



The electricity connection is at the expense of the customer.

To make the electrical connection, the electrical cable (which must comply with the specifications given in chapter [2.2](#)) must be connected to the appropriate connectors, which must be connected to the controller in the direction of connection. Here's an outline of what connector pins do:

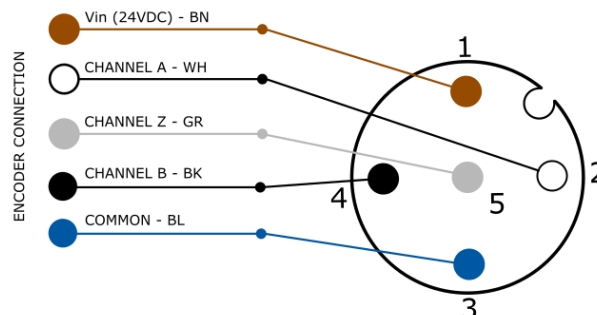
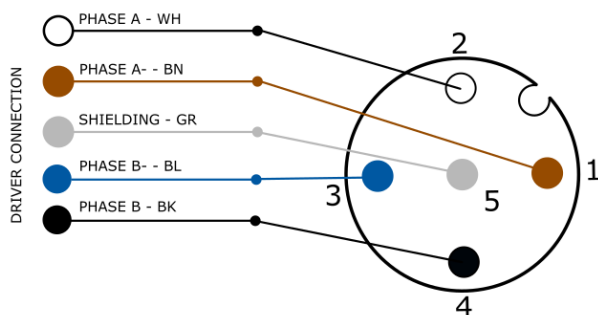

5.3 Commissioning

The commissioning of the component is carried out once the positioning and connection of the connections has been completed. Before commissioning the component, the following checks must be carried out:

- Check that the connections have been connected correctly;
- Check that the component is free of dirt or residues of various kinds;
- Check that the dispensing system is securely connected to the component;



ATTENTION!

If even one of the above points does not comply, commissioning must not be carried out. Commissioning should only be carried out when all points have been successfully completed.

6 SOFTWARE

N.A.

7 PROCEDURE

In this chapter we want to explain the main configurations that can be used on the component covered by this manual. In particular, we want to explain in detail:

- How to perform the cartridge change;
- How to install the mixer locking block;
- How to adjust the height of the mixer closure block and nozzle holder;

7.1 Cartridge change

In this system, whether with or without a mixer closing bracket, the cartridge change method is the same. First, you have to bring the pistons back to the starting point using software and then unscrew the mixer from the special ring nut that keeps it fixed to the cartridge and remove the cartridges following the appropriate guide. Then the cartridges are inserted, the mixer is put back in the appropriate position and the pistons are commanded, by software, to lower the pistons.



ATTENTION!

The new cartridge must be inserted in the same direction as the previous one, as the fluid thrust pistons may be different sizes and can lead to incorrect dosages or pistons that cannot fit inside the cartridge hole.

7.2 Installation of the mixer closing bracket

To install the mixer closing bracket you must have two special screws, usually supplied with the bracket, and it must be positioned in the lower rear part of the extruder. It is advisable to insert the screws in place first, and then screw them inside the appropriate pipes

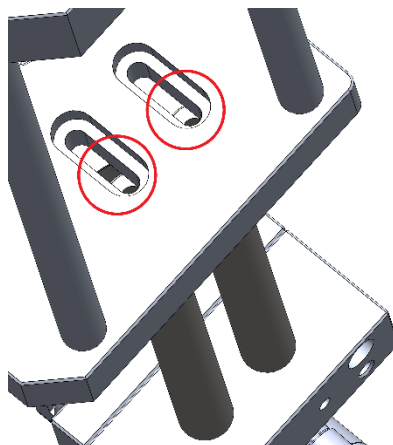

7.3 Height adjustments

In this chapter we want to explain how to adjust the height of the entire mixer closure block and only the height of the nozzle holder. Starting from the mixer closing block, the grub screws placed inside the support blocks, where two cylindrical supports slide, must be loosened, bring the block to the desired height and then fix the grub screws, to keep it in place.

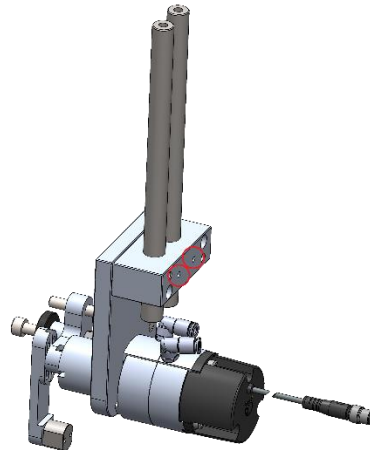

To adjust the height of the mixer holder, on the other hand, you must act on the fixing screws located inside an adjustment guide. By loosening those, you can raise or lower the mixer holder, to adapt it to your needs

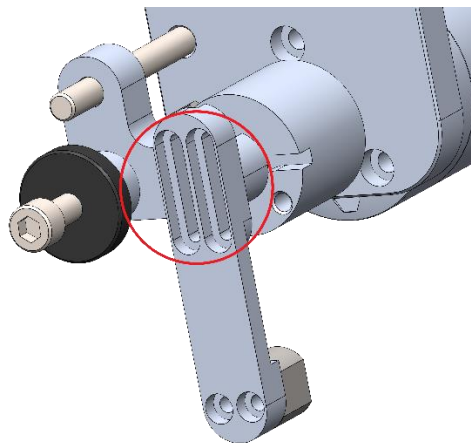

8 MAINTENANCE

Maintenance interventions are all those activities that must be performed on the component which, if carried out correctly, allows it to have a longer life. In general, maintenance is divided into two groups:

- **Ordinary maintenance**, which are interventions on a regular basis or that can be carried out by the customer's staff, are the most important activities as they allow the component to be kept in good working condition;



ATTENTION!

Ordinary maintenance must be carried out in the manner and timing indicated in the following chapters.

- **Extraordinary maintenance**, i.e. all those interventions that are not regularly carried out or that have not been planned, or interventions that cannot be carried out by the Customer. They can also arise from the lack of routine maintenance.



ATTENTION!

Extraordinary maintenance work must be carried out together with the manufacturer's specialized technicians.

Regarding attendance, it must be considered that:

- **When necessary:** Operation to be carried out when the need to be carried out is seen;
- **Every machine start or job end:** Indicates a daily period, in general. This can imply every 24 hours (i.e. at the beginning of the shift of every day, or the end of the shift of every day), or even more frequently, depending on the application;
- **Long pause:** Indicates a period approximately greater than an hour;
- **Each drum change:** Indicates each time the fuel system (tank, drum, cartridge or other) is changed;
- **Each mixer disassembly:** Indicates that each time the mixer is replaced, a certain operation must be performed;
- **Weekly:** Indicates a period equal to seven calendar days;
- **Monthly:** Indicates a period equal to one calendar month;
- **Semi-annual:** Indicates a period equal to six calendar months;
- **Yearly:** Indicates a period equal to one calendar year.



ATTENTION!

The times given below are indicative as they depend on how the component is used. Follow the variations suggested by the technicians.

Assigned	Description	Frequency	Chapter
	Perform a surface cleaning	Every machine start-up or end of work	\
	Pneumatic and fluidic system control	Every machine start-up or end of work	\



ATTENTION!

Only use soft brushes or cotton cloths to clean the dosing system.

9 TROUBLESHOOTING

This chapter deals with the most common problems that may arise when using the component of this manual.



ATTENTION!

Once the operator has found a problem or assumes that there is a problem, they must call the technician in charge of maintenance. Maintenance should always be performed by a specialized and qualified technician.

DEFECT	CAUSE	SOLUTION
Engine won't start	Incorrect motor connection	Check engine connection
Engine does not register its position correctly	Poorly connected encoder	Check encoder connection
The extruder moves during processing	Fixing screws not pulled correctly	Pull set screws
Pistons do not push fluid out of the cartridge	Pistons stuck inside the cartridge	Check that the cartridge is perpendicular to the pistons and that it is securely fastened inside its housing
	Solid or too viscous fluid	Change cartridge
Valve closure does not work properly	Pneumatic air too low	Check that the minimum pressure is respected (chap. 2)
	Defective connection pipes	Changing pneumatic hoses
	Catalyzed/hardened fluid	Replace valve
	Tubes exchanged	Reverse pipes and check that the connections are as per the manual

10 END OF LIFE

End-of-life refers to all those activities that put the component out of service. End-of-life activities can be:

- **Storage**, i.e. when the component is placed inside the warehouse for an unspecified period waiting for a third party to buy the component;
- **Dismantling**, i.e. when the component has reached the end of work period, whether it is due to age, obsolescence or faults that cannot be repaired, or that it is possible to repair but it is worth buying a new component.

If installation is not planned soon, the component can remain packaged and must be stored in a sheltered and preferably closed place. The ambient temperatures to be observed are given in [chapter 2.2](#).

On the other hand, for the dismantling and consequent scrapping of the component or its parts, the different nature of the various components must be considered, and a differentiated scrapping must be carried out. We recommend that you commission specialist companies for this purpose and must always observe the applicable laws on waste disposal.