

USE AND MAINTENANCE MANUAL

FLUIDIC PRESSURE REDUCER DAT-090



Summary

- 1 GENERAL INFORMATION..... 1**
 - 1.1 SYMBOLOGY..... 2
 - 1.2 REFERENCE STANDARDS 3
 - 1.3 DECLARATION OF INCORPORATION (ANNEX II B DIR. 2006/42/EC) 4
 - 1.4 GLOSSARY..... 5
 - 1.5 SERVICE AND MANUFACTURER CONTACT DETAILS 6
- 2 PRESENTATION AND OPERATION 7**
 - 2.1 EXPLODED..... 10
 - 2.2 TECHNICAL DATA 12
- 3 SAFETY 14**
 - 3.1 MACHINE SAFETY DEVICES..... 16
 - 3.2 FREE USEFUL SPACES 16
 - 3.3 RISK AREAS AND RESIDUAL RISK 16
- 4 TRANSPORT AND HANDLING..... 16**
- 5 INSTALLATION 17**
 - 5.1 POSITIONING..... 17
 - 5.2 CONNECTIONS..... 17
 - 5.2.1 *Fluidic* 17
 - 5.3 COMMISSIONING..... 18
- 6 SOFTWARE..... 18**
- 7 PROCEDURE 19**
 - 7.1 PRESSURE REDUCER ADJUSTMENT 20
- 8 MAINTENANCE 21**
 - 8.1 DISASSEMBLY AND REASSEMBLY OF THE COMPONENT..... 23
- 9 TROUBLESHOOTING..... 24**
- 10 END OF LIFE 25**

1 GENERAL INFORMATION

This manual contains information regarding the installation, use, maintenance and end of life of the component and provides indications for the most suitable behavior for correct operation. This manual has been designed to be simple and as straightforward as possible, with a subdivision into chapters and sub-chapters that allows you to find any information you need quickly. In addition, the manual begins by giving a general description of the contents, then an overview of the component, to arrive at aspects of safety, transport, installation and use and finally to the end of life. If you have any doubts about the interpretation or reading of this document, please contact the manufacturer.



DAV Tech declines any responsibility relating to improper use of the component. Observe the specifications in this manual.



Read this manual before handling the component or performing any action on it.



The manual is an essential safety requirement and must accompany the component throughout its life cycle.

It is the task of the end user to optimize the functionality of the component, always considering the purpose for which it was built.



You are asked to keep this manual, together with the attached documentation, in good condition, legible and complete. In addition, it must be stored in the vicinity of the component or, in any case, in a place accessible and known to all personnel who use the component itself or who must perform maintenance or inspection interventions. If the manual deteriorates or is no longer complete, a copy must be requested from the manufacturer, indicating the code of the manual and the revision.



The manual is intended for personnel who use the component (operators), who perform maintenance on it (maintenance technicians), and for personnel who must perform checks or inspections. The manufacturer is not liable for damage to the component caused by personnel who have not followed the instructions in the manual.

If you have any doubts about the correct interpretation of the information contained in this manual, please contact the manufacturer.

GUARANTEE

During the design phase, a careful choice of materials and components to be used in the project was made and they were subjected to regular testing before delivery. All elements have been designed and manufactured with an adequate degree of safety, such as to be able to withstand stress greater than those of normal use.

The warranty is valid for a period of 12 months from the date of commissioning and in any case no longer than 15 months from the date of delivery. Work carried out during the warranty period does not extend the warranty period in any way.

The manufacturer is not liable for defects due to normal wear and tear of parts which, by their nature, decay.

1.1 Symbology

Below are the symbols that are used to give a greater impact to the importance of the concept you want to give.



ATTENTION!

Refers to a warning that could lead to minor damage (minor injuries, damage to the component requiring maintenance work).



DANGER!

It refers to a major event that could cause major damage (death, permanent injury, irreversible breakage of the component).



NOTE. Indicate relevant information or insight.



OBLIGATION. It indicates a task that must be performed, related to both the component and the manual.



REFERENCE. Links to an external document that is important to view

In addition, the list of symbols is integrated with that of the personnel responsible for using the component and its function, together with other symbols used within the manual.



Operator

A (qualified) person capable of operating the component, adjusting, cleaning, starting or resetting the component. The operator is not authorized to perform maintenance.



Mechanical maintenance technician

Qualified technician able to carry out mechanical, adjustment, maintenance and routine repair work described in this manual. He is not authorized to carry out interventions on electrical systems in the presence of voltage.



Electrical maintenance technician

Qualified technician able to carry out electrical, adjustment, maintenance and routine repair work described in this manual. It can work in the presence of voltage on electrical cabinets and junction boxes. He is not authorized to carry out interventions on the mechanical side.



Manufacturer's technician

Qualified technician made available by the manufacturer to carry out operations of a complex nature in particular situations, or in any case as agreed with the customer.

1.2 Reference standards

The reference standards and directives of this manual are the following:

Directives

- 2006/42/EC – Machinery Directive;

1.3 Declaration of incorporation (Annex II B DIR. 2006/42/EC)

Manufacturer's name: DAV Tech Srl
Address: Via G. Ravizza, 30, .36075, Montecchio Maggiore (VI)

DECLARES THAT THE ALMOST MACHINE

Component: DAT-090A, DAT-090B, DAT-090C
Model: Fluidic pressure reducer/stabilizer
Year: 2025
Intended use: Pressure reducer from medium-high to medium-low

COMPLIES WITH THE INCORPORATION PROVISIONS OF DIRECTIVE 2006/42/EC

The technical documentation has been drawn up in accordance with Annex VII B, as required by the following:

- Machinery Directive 2006/42/EC of the European Parliament and Council of 17 May 2006

IT ALSO DECLARES THAT:

- Undertakings are undertaken to provide, in response to a properly substantiated request from the national authorities, relevant information on this partly completed machine;
- The technical file was prepared by Andrea Grazioli, via Ravizza, 30, Montecchio Maggiore (VI), IT.

This quasi-machine cannot be used until the machinery on which it will be used is declared compliant with regulation 2006/42/EC.

Montecchio Maggiore, 28 January 2025

The legal representative

Andrea Grazioli

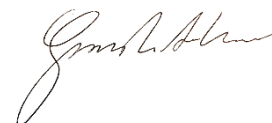

COD.: DTVI_DAT090_2505
REV.: 00
DATE: 29/01/2025

DAV TECH SRL
Any reproduction (total or partial) of this document not authorized by the manufacturer will be punished according to the law.



1.4 Glossary

The following are the most used terms within this manual with their meanings.

TERM	DEFINITION
Enable	Term that defines the act of preparing (enabling) an action. The action will be triggered as soon as the criteria are met, which consequently leads to the activation of the enabled action.
Active	The action that is performed instantaneously when the control is activated.
Human controls	This defines those commands that, used for manual operations, must be kept activated for the action to be performed. When the command is released, the action stops.
Two-hand controls	Human-controlled controls that require two manual controls to be operated simultaneously to perform an action.
P.P.E.	Personal protective equipment. They include all the items necessary to ensure the protection of personnel from possible accidental damage (safety shoes, gloves, helmet, and more).
Display	It is used to display information. It can be in any shape and size, even touch screen.
Manufacturer	Natural or legal person who designed and manufactured the component covered by this manual.
HP	High Pressure. An acronym that indicates high pressure.
Icon	A small image that represents a command, a function or even a document or an operating program, which appears on a computer screen. When selected by the user, it initiates the function or program it symbolizes.
Joystick	Lever manipulator used in control panels.
N.A.	Not Applicable, i.e. it indicates that it is a field that does not apply to this manual and that it cannot be integrated into the component.
Operator panel	A control station where the machine control instruments are located
P.I.	Possible Implementation, i.e. it is currently absent from the component described in this manual, but it is possible to make an addition and implement it.
Screen	Interface system between man and component. Screenshots are the images displayed on the operator panel that allow the user to receive and provide information to the management software.
Push-button panel	Composition of buttons and selectors that allow you to act directly on the behavior of the component.
Keyboard	Keyboard only (stand-alone element) or in addition to a display (keys only, no selectors or other)
Touch screen	Touch screen that allows the user to interact with a graphic interface using their fingers or objects.

1.5 Service and manufacturer contact details

For any reason relating to the use, maintenance or request of spare parts, the customer must contact the manufacturer (or the service center if present) directly, specifying the identification data of the component.

The customer can make use of the technical and commercial support of local agents or importers, who are in direct contact with the company DAV Tech Srl.

Company name	DAV Tech Srl
Postal address	Via Ravizza, 30, 37065, Montecchio Maggiore (VI) – (IT)
Telephone	+39 0444 574510
Fax	+39 0444 574324
email	davtech@davtech.it
Website	www.davtech.it

2 PRESENTATION AND OPERATION

In this manual we want to deepen the operation of DAT-090 fluidic pressure reducers, which are used to reduce the pressure of the fluid that passes through them. This type of component can work with various types of fluids, as described in [chapter 2.2](#).

In other words, the function of this component is:

REDUCE THE FLUIDIC PRESSURE OF THE PASSING FLUID.

Intended use is the use described in the chapter below, while improper use is considered any other use that is not described in this manual, with products of different material and format from those for which it was built.

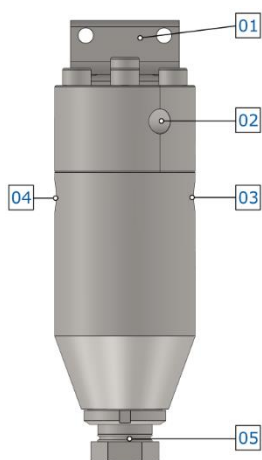

No. DESCRIPTION

01	Support bracket
02	Fluid inlet
03	Fluid output
04	Fluid output
05	Fluidic pressure adjustment knob

Figure 01 – Detail DAT-090

Before using a certain type of fluid, it is necessary to check that:

- The viscosity of the fluid is compatible with the characteristics of the valve;
- The characteristics of the fluid meet the desired requirements;
- The technical data sheet of the fluid provided by the manufacturer contains all the information regarding the product such as viscosity, applications, drying times and storage;
- The fluid storage time has not been exceeded;
- The fluid packages are tightly sealed.

If it is necessary to use several fluids with the same valve, it must be cleaned thoroughly to prevent residues from the previous processing from affecting the processing to be performed.

SPECIAL VERSIONS

This component can be supplied in 3 variants, based on the fluidic pressure range that you want to have at the exit of the component itself. For more information, see [chapter 2.2](#)

OPERATION

This component must be connected to two fluidic systems, of which the inlet is connected on one side, while the outlet is connected on the other (generally, the inlet connects to the supply system, which can be a PP pump, while the outlet goes to the dosing system). It does not need pneumatic connections, as this component is mechanically managed.

For minimum working pressures, please refer to [Chapter 2.2](#).

The component cannot operate autonomously. To ensure that it works properly, it must be connected to a fluidic source, such as a PP pump, and to the dosing system.



ATTENTION!

It is recommended that you connect the component to the sources indicated in this manual in [chapter 2.2](#). Connecting them to other sources or products with features not listed in this manual may break them.

The following is intended to explain how the DAT-090 component works.

This component consists of a spring loaded by a knob screw, which acts on an internal piston that presses a ball valve (counterbalanced by a conical spring), which regulates the flow of the fluid. Based on the displacement of the ball, the outlet pressure of the fluid is decided, which is counterbalanced by the pressure of the incoming fluid and the conical spring present under the ball itself. An increase in the outlet pressure causes the piston to move, which closes the ball valve and, therefore, the interruption of the outgoing fluid.

USEFUL TIPS

P.I.

PRESSURE PLATE PUMP

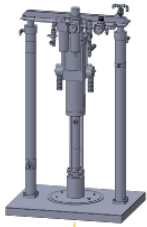

MANOMETER



DOSING SYSTEM

DAT-090

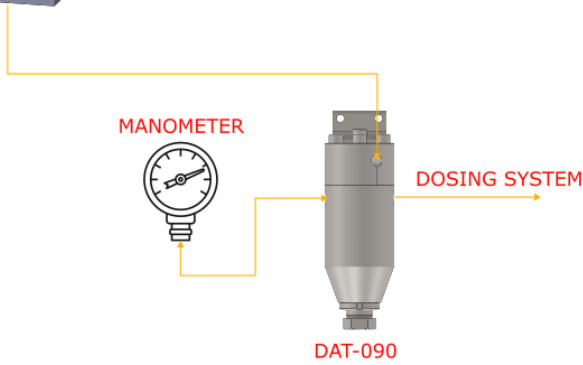

COLOR	MEANING
YELLOW	Product
RED	Notes

Figure 02 – Connection Example

2.1 Exploded

The following is a list of the main valve components with spare part numbers.

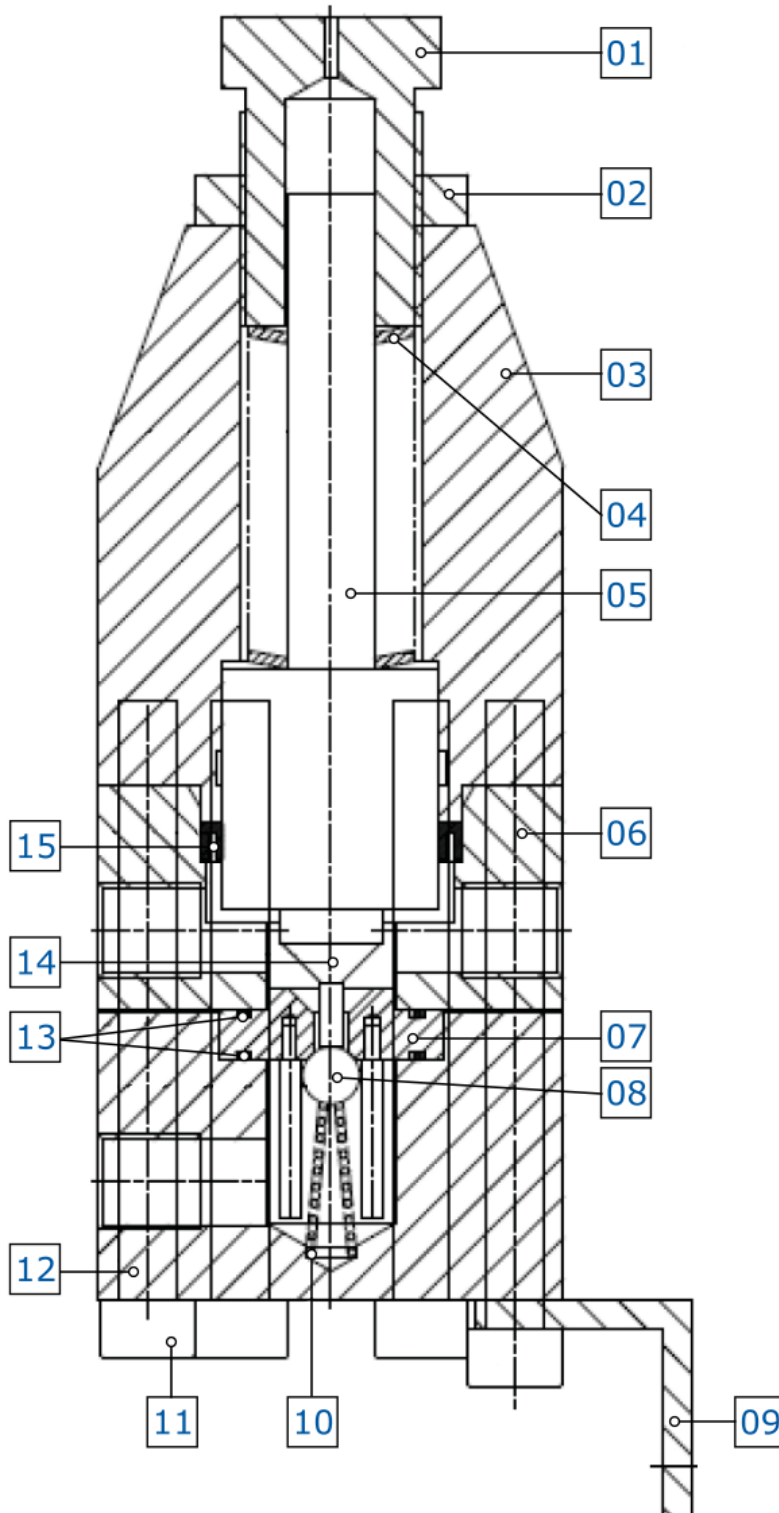

No.	Description	Var.	Code	Variant details
01	ADJUSTMENT SCREW	-	B59403	-
02	M25 RING NUT	-	K30362A	-
03	UPPER BODY REDUCER	-	B59122	-
04	DISC SPRING ⁽¹⁾	-	H26602	-
05	HARDENED BOLT PISTON	-	B59553	-
06	CENTRAL BODY GEARBOX	-	B59022	-
07	FULL HARDENED BALL SEAT	-	T604400	-
08	5/16" CARBIDE BALL	-	K81304	-
09	SUPPORT	-	E50662	-
10	VALVE SPRING	-	H21803A	-
11	SCREW	-	K13962	-
12	LOWER BODY REDUCER	-	B58922	-
13	O-RING	-	L14906	-
14	SHUTTER ROD	-	B61903	-
15	O-RING	-	L41808	-

⁽¹⁾ For disc springs, see the following diagram for the number and direction of insertion:

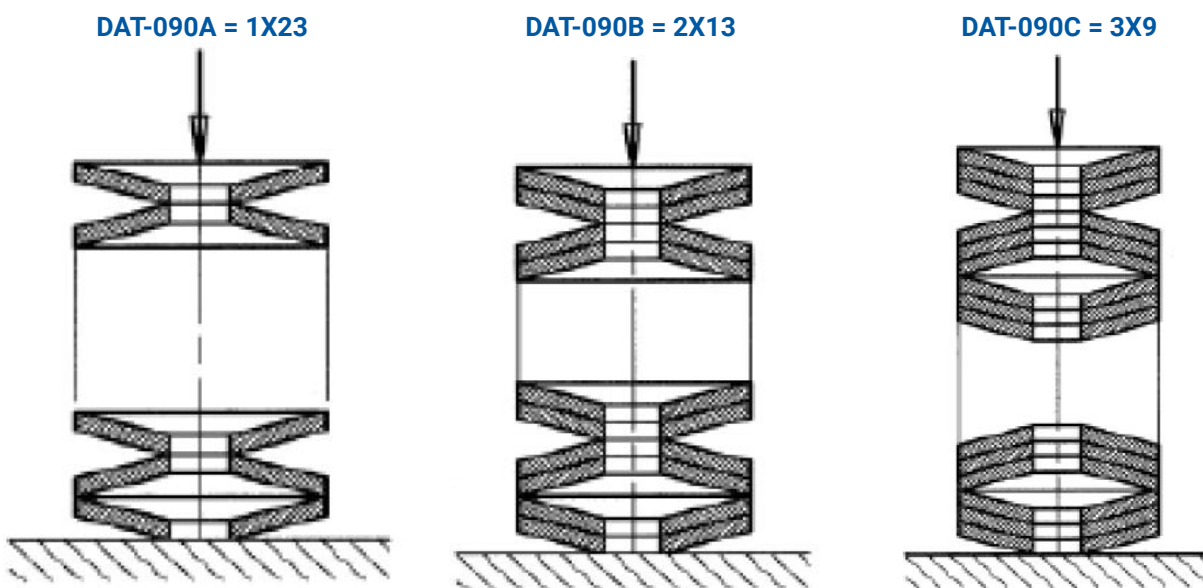

2.2 Technical data

All the technical characteristics concerning the component of this manual are indicated below.

SPECIFICATIONS		
Description	UdM	Values
Model	\	DAT-090
Activation	\	Mechanic
Maximum Inlet Fluid Pressure	bar	300
Outlet pressure adjustment range DAT-090A	bar	10 ÷ 60
Outlet pressure adjustment range DAT-090B	bar	30 ÷ 120
Outlet pressure adjustment range DAT-090C	bar	40 ÷ 180
Product inlet thread	inch	G 1/4" F
Product output thread	inch	G 1/4" F
Pressure gauge connection thread	inch	G 1/4" F
Passage adjustment	\	Screw
Materials used	\	Carbon Steel
		PE
		Tungsten carbide
		Hardened steel

ENVIRONMENTAL CHARACTERISTICS		
Description	UdM	Values
Working Ambient Temperature	°C	5 ÷ 45
Storage Ambient Temperature	°C	-20 ÷ 55
Permissible non-condensing humidity	%	5 ÷ 90

USABLE FLUIDS		
Silicones		
Liquid gaskets		
Greases		
Resins		

Various medium-high viscosity products (contact the manufacturer for more information)

DIMENSIONAL AND WEIGHT CHARACTERISTICS

Description	UdM	Value
Component length (min ÷ max)	mm	65
Component depth (min ÷ max)	mm	82
Component height (min ÷ max)	mm	204
Component weight	kg	3.43

Component

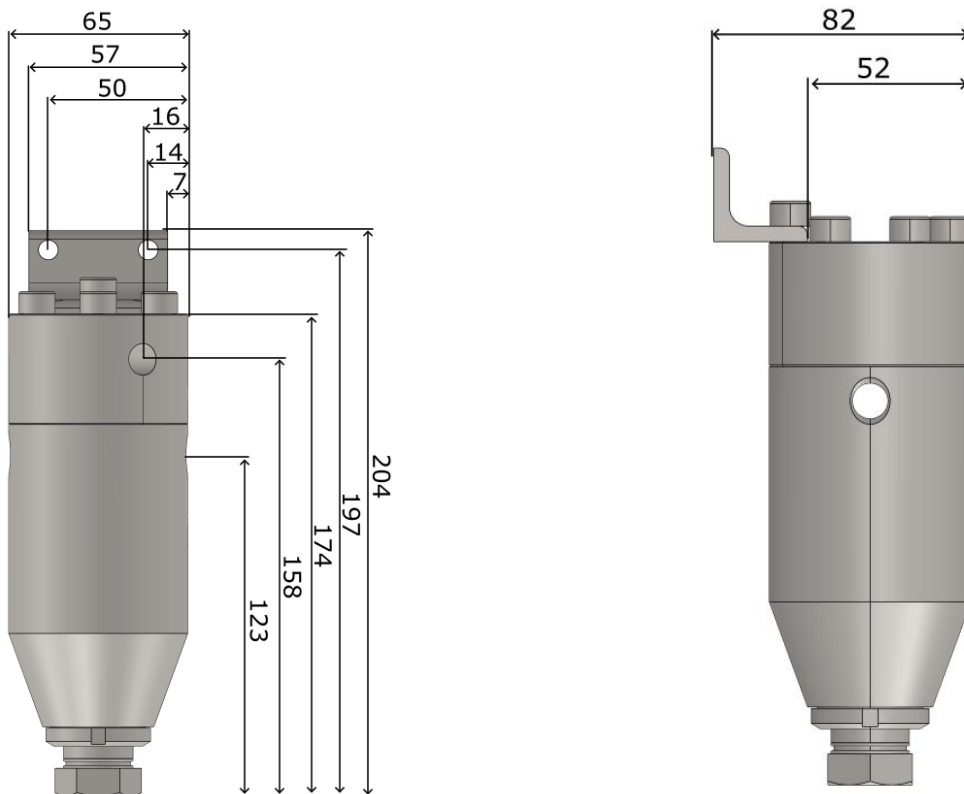

You can request the 3D of the component in the desired version from the manufacturer without any obligation.

3 SAFETY

The following is a list of warnings regarding the component covered by this manual. Please read carefully before proceeding to the next chapters.



DANGER!

Before operating the component or performing any action on it, read this manual carefully.



DANGER!

Do not use the component while under the influence of drugs or other substances that may impair attention and reaction ability.



DANGER!

Operators must only perform operations or interventions that are within the competence of the role and qualification assigned.



FIRE/EXPLOSION HAZARD!

This component is not designed to work in an ATEX environment.



DANGER!

Be very careful when servicing the component, especially when disassembling components that have pressure springs inside.



DANGER!

Do not use fluids that react in contact with the materials indicated in [chapter 2.2](#)



DANGER!

Never exceed the maximum pump pressure given in [chapter 2.2](#)



DANGER!

If fluids are used at high temperatures, the pump can reach temperatures that can cause burns if touched.



DANGER!

Do not use chlorinated and halogenated solvents (e.g., Trichloroethane and Methylene Chloride) with equipment that contains aluminum or galvanized and galvanized parts, as they can react chemically and cause an explosion.



ATTENTION!

Modifications to the component must not be made to achieve performance other than that for which it was designed and built, unless authorized by the manufacturer.

**ATTENTION!**

Avoid introducing foreign bodies, even small ones, into the pneumatic system, which could cause the system to malfunction and compromise the safety of the machine.

**ATTENTION!**

Check the chemical compatibility of the materials with which the pump is made with those of the fluid in use

**ATTENTION!**

Make sure the pipes are in good condition and not worn



The component may only be used by trained and authorized operators and for the sole purpose for which it was designed and manufactured.



The component is manufactured in compliance with the technical safety standards in force at the time of its construction.

3.1 Machine safety devices

N.A.

3.2 Free useful spaces

N.A.

3.3 Risk areas and residual risk

N.A.

4 TRANSPORT AND HANDLING

Once you have received the goods, you must check that the packaging is intact and that there is an exact correspondence with the material ordered.



ATTENTION!

The original configuration of the component must not be changed. The manufacturer is not liable for damage caused by inappropriate use of the component.



ATTENTION!

If the packaging is not intact, contact the manufacturer immediately, also sending photos of the condition of the packaging. Do not open it until you have notified the manufacturer.

5 INSTALLATION

The installation of the component is carried out by the customer. If necessary, you can contact the manufacturer to have a specialist technician help you.

The component has been designed to work vertically, i.e. in such a way that its body is perpendicular to the ground. In addition, it is equipped with a bracket that has two Ø7mm through holes that allow the component to be installed both on the wall and on a secondary bracket.

It is recommended that you perform a component check before beginning the installation. If it is evidently damaged, please contact the manufacturer.

ATTENTION! Please remove the packaging with the utmost care. If damage is caused to the component, the manufacturer is not liable.

Dispose of the packaging correctly, considering the different nature of the components and following the regulations in force in the country.

5.1 Positioning

N.A.

5.2 Connections

In this chapter, we want to explain the connection method that must be used for the component. The following types of connection are provided:

- Fluid connection

5.2.1 Fluidic

Authorized personnel		PPE to wear					
Component status	Installed component						
Power Values	See chapter 2.2						
Necessary preparations	Fluidic system ready for connection						
Materials needed	Tightening wrenches						
Equipment needed	N.A.						

The fluidic connection is the responsibility of the customer.

To make the fluidic connection, the pressure gauge must be connected to one of the two outlets, while the delivery pipe to the dosing system must be connected to the other; the inlet must be connected to the pipes going to the supply system. For hole sizes, see [chapter 2.2](#)

5.3 Commissioning

The commissioning of the component is carried out once the positioning and connection of the connections has been completed. Before commissioning the component, the following checks must be carried out:

- Check that the connections have been connected correctly;
- Check that the component is free of dirt or residues of various kinds;



ATTENTION!

Since the component is being tested with oil, it is recommended that you connect the fuel system to a purge system and clean the component by performing a few purge cycles.



ATTENTION!

If even one of the above points does not comply, commissioning must not be carried out. Commissioning should only be carried out when all points have been successfully completed.

6 SOFTWARE

N.A.

7 PROCEDURE

In this chapter we want to explain the main configurations that can be used on the component covered by this manual. We want to explain in detail:

- How to adjust the pressure reducer;

7.1 Pressure reducer adjustment

In this section we want to explain how to adjust the pressure reducer. This adjustment is essential to have the desired fluidic pressure at the outlet, as well as to prevent the dosing system. Care should be taken to stay within the parameters set out in [chapter 2.2](#).

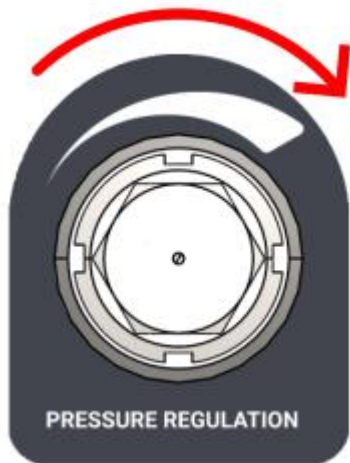

If you turn clockwise, you increase the pressure inside the pressure reducer; therefore, you go from a lower pressure to a higher one.

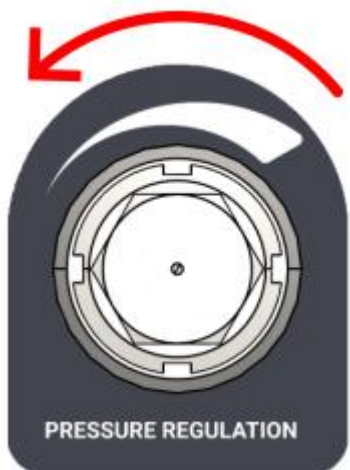

If you turn counterclockwise, you decrease the pressure inside the pressure reducer; therefore, you go from a higher pressure to a lower one.



It is advisable to always adjust the pressure in INCREASE, i.e. if you have to decrease the pressure or have exceeded the threshold you want to set, you must first decrease the pressure below the threshold you want to work at and then increase the pressure to the set value. To do otherwise you risk having a negative oscillation of the pressure, therefore stabilizing at an incorrect value and lower than you would like.

8 MAINTENANCE

Maintenance interventions are all those activities that must be performed on the component which, if carried out correctly, allows it to have a longer life. In general, maintenance is divided into two groups:

- **Ordinary maintenance**, which are interventions on a regular basis or that can be carried out by the customer's staff, are the most important activities as they allow the component to be kept in good working condition;



ATTENTION!

Ordinary maintenance must be carried out in the manner and timing indicated in the following chapters.

- **Extraordinary maintenance**, i.e. all those interventions that are not regularly carried out or that have not been planned, or interventions that cannot be carried out by the Customer. They can also arise from the lack of routine maintenance.



ATTENTION!

Extraordinary maintenance work must be carried out together with the manufacturer's specialized technicians.



Regarding attendance, it must be considered that:

- **When necessary**: Operation to be carried out when the need to be carried out is seen;
- **Every machine start or job end**: Indicates a daily period, in general. This can imply every 24 hours (i.e. at the beginning of the shift of every day, or the end of the shift of every day), or even more frequently, depending on the application;
- **Long pause**: Indicates a period approximately greater than an hour;
- **Each drum change**: Indicates each time the fuel system (tank, drum, cartridge or other) is changed;
- **Each mixer disassembly**: Indicates that each time the mixer is replaced, a certain operation must be performed;
- **Weekly**: Indicates a period equal to seven calendar days;
- **Monthly**: Indicates a period equal to one calendar month;
- **Semi-annual**: Indicates a period equal to six calendar months;
- **Yearly**: Indicates a period equal to one calendar year.



ATTENTION!

The times given below are indicative as they depend on how the component is used. Follow the variations suggested by the technicians.

Assigned	Description	Frequency	Chapter
	Perform a component function test	Every machine start-up or end of work	\
	Perform a surface cleaning of the component	Every machine start-up or end of work	\
	Perform an internal cleaning cycle of the component	Every machine start-up or end of work	\
	Disassembly and reassembly of the valve	Annual	8.1

ATTENTION!



It is very important that for long breaks (depending on the type of fluid used, see the technical data sheet) you perform an internal cleaning of the component, especially if you have products that tend to cross-link, with special solvents (depending on the product used). If this is not done, there is a risk of a malfunction of the component itself, which leads to a complete overhaul of the component or replacement of the component.



ATTENTION!

Only use soft brushes or cotton cloths to clean the valve.

8.1 Disassembly and reassembly of the component

Assigned	Periodicity	Materials and equipment
	Annual	N.A.

PPE to wear



The disassembly and reassembly of the component is very intuitive, based on the exploded view of [chapter 2.1](#). Some aspects to pay particular attention to:

- **Disc springs**, which must comply with the mounting direction indicated in the same chapter.
- **The tightening screws**, which MUST be pulled up to 35 Nm, as indicated in the same chapter;
- **The adjustment ball**, this component is made of tungsten carbide, which is very delicate. If it falls to the ground or suffers shocks, it risks splintering, which will then affect the quality of operation of the product;
- **The spring of the ball**, which is slightly conical. This taper must be respected when it is reassembled, otherwise the effectiveness of the ball will be lost.

9 TROUBLESHOOTING

This chapter deals with the most common problems that may arise when using the component of this manual.



ATTENTION!

Once the operator has found a problem or assumes that there is a problem, they must call the technician in charge of maintenance. Maintenance should always be performed by a specialized and qualified technician.

DEFECT	CAUSE	SOLUTION
Outlet fluid pressure drop	Locking the ball in its seat	Disassemble the component and clean it.
	Obstruction of the passage from foreign bodies	
The fluid outlet pressure increases to the level of the inlet fluid pressure	The valve ball and seat are worn or stuck	Remove the pressure and screw the regulator as far as it will go and then unscrew it.
		Clean the ball and seat, replacing worn or damaged parts.
	The disc springs are worn	Replace the springs
Fluid outlet from the control hole	Worn gasket	Replace the gasket

10 END OF LIFE

End-of-life refers to all those activities that put the component out of service. End-of-life activities can be:

- **Storage**, i.e. when the component is placed inside the warehouse for an unspecified period waiting for a third party to buy the component;
- **Dismantling**, i.e. when the component has reached the end of work period, whether it is due to age, obsolescence or faults that cannot be repaired, or that it is possible to repair but it is worth buying a new component.

If installation is not planned soon, the component can remain packaged and must be stored in a sheltered and preferably closed place. The ambient temperatures to be observed are given in [chapter 2.2](#).

On the other hand, for the dismantling and consequent scrapping of the component or its parts, the different nature of the various components must be considered, and a differentiated scrapping must be carried out. We recommend that you commission specialist companies for this purpose and must always observe the applicable laws on waste disposal.